

BY-LAW NO.131-1989, OF THE CITY OF CORNWALL

A By-law to amend By-Law No. 069, 1989  
as amended.

\* \* \* \* \*

The Council of the Corporation of the City of Cornwall enacts as follows:

1. Schedule XIV (Through Highways) of By-law No. 069, 1989 is hereby amended by repealing the following:

<u>COLUMN I</u> <u>HIGHWAY</u>	<u>COLUMN II</u> <u>FROM</u>	<u>COLUMN III</u> <u>TO</u>
Eleventh Street	West side of Hebert St.	West side of Cumberland St.

2. Schedule XV (Stop Signs) of By-law No. 069, 1989 is hereby amended by repealing the following:

<u>COLUMN I</u> <u>INTERSECTION</u>	<u>COLUMN II</u> <u>FACING TRAFFIC</u>
Gardner Ave. and Walton St.	Northbound and southbound on Walton St.
Holy Cross Blvd. and Paulette St.	Northbound and southbound on Paulette St.

3. Schedule XV (Stop Signs) of By-law No. 069, 1989 is hereby amended by adding thereto the following:

<u>COLUMN I</u> <u>INTERSECTION</u>	<u>COLUMN II</u> <u>FACING TRAFFIC</u>
Capt.MacDonald Rd. and Eleventh St.	Southbound on Capt.MacDonald Rd.
Eleventh St. West and Ninth St. North	Eastbound and westbound on Eleventh Street West
Gardner Ave. and Walton St.	Northbound and southbound on Gardner Avenue
Hebert St. and Eleventh St. West	Southbound on Hebert St.
Holy Cross Blvd. and Dean Dr.	Northbound on Dean Dr.
Ninth St. West and Ninth St. North	Southbound on Ninth St. North

- 4. Schedule XXV (Connecting Links) of By-law No. 069, 1989 is hereby amended by repealing the following:

<u>COLUMN I</u> <u>HIGHWAY</u>	<u>COLUMN II</u> <u>FROM</u>	<u>COLUMN III</u> <u>TO</u>
Brookdale Avenue	Second Street	Cornwall Centre Road
Vincent Massey Drive	Thirteenth Street	West City limit (Part of Highway #2)

- 5. Schedule XXV (Connecting Links) of By-law No. 069, 1989 is hereby amended by adding thereto the following:

<u>COLUMN I</u> <u>HIGHWAY</u>	<u>COLUMN II</u> <u>FROM</u>	<u>COLUMN III</u> <u>TO</u>
Brookdale Avenue	Second Street	Highway #401 Interchange
Vincent Massey Drive	Brookdale Avenue	West City limit (Part of Highway #2)

- 6. Schedule XVI (Yield Signs) of By-law No. 069, 1989 is hereby amended by adding thereto the following:

<u>COLUMN I</u> <u>INTERSECTION</u>	<u>COLUMN II</u> <u>FACING TRAFFIC</u>
Brookdale Ave. and Ninth St.	Northbound on Brookdale Ave. turning east
Brookdale Ave. and Ninth St.	Southbound on Brookdale Ave. turning west

READ a First and Second Time in Open Council this 11th day of September, 1989 A.D.

  
CLERK

  
MAYOR

READ a Third Time, Passed and Sealed in Open Council this 11th day of September, 1989 A.D.

  
CLERK

  
MAYOR

A

BYLAW NO.148, 1989 OF THE CITY OF CORNWALL

A bylaw to amend Bylaw No. 069, 1989  
as amended

\* \* \* \* \*

The Council of the Corporation of the City of Cornwall enacts as follows:

1. Schedule VI (School Bus Loading Zones) of Bylaw No. 069, 1989 is hereby amended by repealing the following:

<u>COLUMN I</u>	<u>COLUMN II</u>	<u>COLUMN III</u>	<u>COLUMN IV</u>	<u>COLUMN V</u>
<u>Highway</u>	<u>Side</u>	<u>Between</u>	<u>School or Institution</u>	<u>Prohibited Times Or Days</u>
Surgenor St.	East	A point 59 metres south of Charles Street and a point 24 metres further south	Ecole Ste. Anne	Anytime

2. Schedule VI (School Bus Loading Zones) of Bylaw No. 069, 1989 is hereby amended by adding thereto the following:

<u>COLUMN I</u>	<u>COLUMN II</u>	<u>COLUMN III</u>	<u>COLUMN IV</u>	<u>COLUMN V</u>
<u>Highway</u>	<u>Side</u>	<u>Between</u>	<u>School or Institution</u>	<u>Prohibited Times Or Days</u>
Surgenor St.	East	A point 15 metres south of Charles Street and a point 44 metres further south	Ecole Ste. Anne	Anytime

3. Schedule XII (Designated Traffic Lanes) of Bylaw No. 069, 1989 is hereby amended by adding thereto the following:

<u>COLUMN I</u>	<u>COLUMN II</u>	<u>COLUMN III</u>	<u>COLUMN IV</u>	<u>COLUMN V</u>
<u>Highway</u>	<u>Between</u>	<u>Lane</u>	<u>Direction</u>	<u>Times/Days</u>
Cornwall Centre Road	Pitt Street and Cadeb Avenue	First lane from south curb	East and east to south	Anytime
Cornwall Centre Road	Pitt Street and Cadeb Avenue	Second lane from south curb	East to north and west to south	Anytime
Cornwall Centre Road	Pitt Street and Cadeb Avenue	Third lane from south curb	West and west to north	Anytime

Read a First and Second time in Open Council this 10th day of October, A.D. 1989.



Clerk



Mayor

Read a Third time, PASSED, SIGNED and SEALED in Open Council this 10th day of October, A.D. 1989.

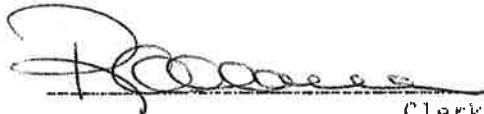

Clerk



Mayor

A

BY-LAW NO. 167 1989 OF THE CITY OF CORNWALL

A By-law to amend By-law No. 069, 1989  
as amended

\* \* \* \* \*

The Council of the Corporation of the City of Cornwall enacts as follows:

1. Schedule XVIII (Heavy Trucks Prohibited) of By-law No. 069, 1989 is hereby amended by adding thereto the following:

<u>COLUMN I</u>	<u>COLUMN II</u>	<u>COLUMN III</u>
<u>HIGHWAY</u>	<u>BETWEEN</u>	<u>PROHIBITED TIMES OR DAYS</u>
Cumberland Street	Eleventh Street and Thirteenth Street	Anytime
Eleventh Street	Cumberland Street and Hebert Street	Anytime

2. Schedule VI (School Bus Loading Zone) of By-law No. 069, 1989 is hereby amended by repealing the following:

<u>COLUMN I</u>	<u>COLUMN II</u>	<u>COLUMN III</u>	<u>COLUMN IV</u>	<u>COLUMN V</u>
<u>HIGHWAY</u>	<u>SIDE</u>	<u>BETWEEN</u>	<u>SCHOOL OR INSTITUTION</u>	<u>PROHIBITED TIMES OR DAYS</u>
Surgenor St.	East	A point 15 metres south of Charles Street and a point 44 metres further south	Ecole Ste Anne	Anytime

3. Schedule II (parking Restrictions) of By-law No. 069, 1989 is hereby amended by adding thereto the following:

<u>COLUMN I</u>	<u>COLUMN II</u>	<u>COLUMN III</u>	<u>COLUMN IV</u>
<u>HIGHWAY</u>	<u>SIDE</u>	<u>BETWEEN</u>	<u>PROHIBITED TIMES OR DAYS</u>
Reneal Street	East	Thirteenth Street and Sunnyside Avenue	Anytime
Marlborough St.	West	Second Street and a point 55 metres south of Second Street	Anytime
Holy Cross Blvd.	North	Lynwood Drive and Glengarry Boulevard	Anytime
First Street	South	A point 48 metres west of Augustus Street and a point 20 metres further west	Anytime
Third Street	North	Amelia Street and Sydney Street	8:00 a.m. - 6:00 p.m. Mon. - Fri.

Read a First and Second time in Open Council this 11th day of December, A.D. 1989.

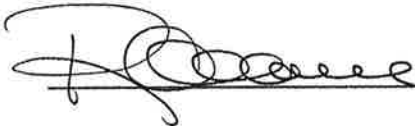
  
Clerk

  
Mayor

Read a Third Time, PASSED, SIGNED and SEALED in Open Council this 11th day of December, A.D. 1989.

  
Clerk

  
Mayor

BYLAW NO. 060, 1990 OF THE CITY OF CORNWALL

A Bylaw to amend Bylaw No. 069, 1989  
as amended

The Council of the Corporation of the City of Cornwall enacts as follows:

1. Schedule XV (Stop Signs) of Bylaw No. 069, 1989 is hereby amended by adding thereto the following:

COLUMN I

Intersection

Billington Drive and  
Concorde Avenue

Sheridan Street and  
Concorde Avenue

Mercier Avenue and  
Northdale Drive

Northdale Drive and  
Forestdale Crescent

COLUMN II

Facing Traffic

Southbound on Billington Drive

Southbound on Sheridan Street

Northbound and southbound on  
Northdale Drive

Westbound on Forestdale Crescent

2. Schedule XVI (Yield Signs) of Bylaw No. 069, 1989 is hereby amended by adding thereto the following:

COLUMN I

Intersection

Fraser Avenue and  
Lynn Street

Lynn Street and  
Jase Street

COLUMN II

Facing Traffic

Northbound on Fraser Avenue

Eastbound on Lynn Street

COLUMN I

COLUMN II

Intersection

Facing Traffic

Glen Oaks Court  
and Lynn Street

Eastbound on Glen Oaks Court

Lynn Street and  
Hamilton Crescent

Northbound on Lynn Street

Northwoods Crescent and  
Wellington Street

Westbound on Northwoods Crescent

Markell Crescent (North)  
and Wellington Street

Westbound on Markell Crescent

Markell Crescent (South)  
and Wellington Street

Westbound on Markell Crescent

3. Schedule XVIII (Heavy Trucks Prohibited) of Bylaw No. 069, 1989 is hereby amended by adding thereto the following:

COLUMN I

COLUMN II

COLUMN III

Highway

Between

Prohibited  
Times or Days

Cumberland Street

Fifteenth Street and  
Emma Avenue

Anytime

Cobble Hill Road

Brookdale Avenue and  
Meadowvale Crescent

Anytime

Emma Avenue

Aubin Avenue and  
Tollgate Road

Anytime

Read a First and Second time in Open Council this 9th day of April, A.D. 1990.

  
Clerk

  
Mayor

Read a Third time, PASSED, SIGNED and SEALED in Open Council this 9th day of April, A.D. 1990.

  
Clerk

  
Mayor

BYLAW NO. 082, 1990 OF THE CITY OF CORNWALL

A Bylaw to amend bylaw No. 069, 1989  
as amended

The Council of the Corporation of the City of Cornwall enacts as follows:

1. Schedule XXII (Pedestrian Crossover) of Bylaw No. 069, 1989 is hereby amended by adding thereto the following:

<u>COLUMN I</u>	<u>COLUMN II</u>
<u>Street</u>	<u>Intersection or Location</u>
Montreal Road	Edward Street (west crosswalk)
Second Street	Domtar main entrance (east crosswalk)

2. Schedule 1 (Stopping Restrictions) of Bylaw No. 069, 1989 is hereby amended by adding thereto the following:

<u>COLUMN I</u>	<u>COLUMN II</u>	<u>COLUMN III</u>	<u>COLUMN IV</u>
<u>Highway</u>	<u>Side</u>	<u>Between</u>	<u>Prohibited Times or Days</u>
Montreal Road	South	Edward Street and a point 35 metres west of Edward St.	Anytime
Montreal Road	North	Edward Street and a point 10 metres east of Edward St.	Anytime
Second Street	South	A point 10 metres east of the east curb of the main entrance to Domtar to a point 37 metres west	Anytime

<u>COLUMN I</u>	<u>COLUMN II</u>	<u>COLUMN III</u>	<u>COLUMN IV</u>
<u>Highway</u>	<u>Side</u>	<u>Between</u>	<u>Prohibited Times or Days</u>
Second Street	North	East curb of the main entrance to Domtar and a point 35 metres east of the east curb of the main entrance to Domtar	Anytime

3. Schedule II (Parking Restriction) of Bylaw No. 069, 1989 is hereby amended by repealing the following:

<u>COLUMN I</u>	<u>COLUMN II</u>	<u>COLUMN III</u>	<u>COLUMN IV</u>
<u>Highway</u>	<u>Side</u>	<u>Between</u>	<u>Prohibited Times or Days</u>
Second Street	North	Cumberland Street and the west limit of Second Street	Anytime
Second Street	South	Cumberland Street and the west limit of Second Street	Anytime

4. Schedule II (Parking Restrictions) of Bylaw No. 069, 1989 is hereby amended by adding thereto the following:

<u>COLUMN I</u>	<u>COLUMN II</u>	<u>COLUMN III</u>	<u>COLUMN IV</u>
<u>Highway</u>	<u>Side</u>	<u>Between</u>	<u>Prohibited Times or Days</u>
Montreal Road	North	A point 10 metres east of Edward St. and a point 21 metres further east	Anytime
Second Street	North	Cumberland Street and a point 35 metres east of the east curb of the main entrance to Domtar	Anytime

<u>COLUMN I</u>	<u>COLUMN II</u>	<u>COLUMN III</u>	<u>COLUMN IV</u>
<u>Highway</u>	<u>Side</u>	<u>Between</u>	<u>Prohibited Times or Days</u>
Second Street	North	East curb of the main entrance to Domtar and the west limit of Second Street	Anytime
Second Street	South	Cumberland Street and a point 10 metres east of the east curb of the main entrance to Domtar	Anytime
Second Street	South	A point 27 metres west of the east curb of the main entrance to Domtar and the west limit of Second Street	Anytime

Read a First and Second time in Open Council this 15th day of May, A.D. 1990.

  
Clerk

  
ACTING MAYOR Mayor

Read a Third time, PASSED, SIGNED and SEALED in Open Council this 15th day of May, A.D. 1990

  
Clerk

  
ACTING MAYOR Mayor

BYLAW NO. 098, 1990 OF THE CITY OF CORNWALL

A Bylaw to amend Bylaw No. 069, 1989  
as amended

\* \* \* \* \*

The Council of the Corporation of the City of Cornwall enacts as follows:

1. Schedule II (Parking Restriction) of Bylaw 069, 1989 is hereby amended by repealing the following:

<u>COLUMN I</u>	<u>COLUMN II</u>	<u>COLUMN III</u>	<u>COLUMN IV</u>
<u>Highway</u>	<u>Side</u>	<u>Between</u>	<u>Prohibited Times or Days</u>
Pitt Street	East	Ninth Street and the north limit of Pitt Street	Anytime
Pitt Street	West	Ninth Street and the north limit of Pitt Street	Anytime
Seventh Street	North	Brookdale Avenue and Amelia Street	Anytime

2. Schedule II (Parking Restrictions) of Bylaw 069, 1989 is hereby amended by adding thereto the following:

<u>COLUMN I</u>	<u>COLUMN II</u>	<u>COLUMN III</u>	<u>COLUMN IV</u>
<u>Highway</u>	<u>Side</u>	<u>Between</u>	<u>Prohibited Times or Days</u>
Pitt Street	West	Ninth Street and Fennell Crescent	Anytime
Pitt Street	West	Crescent view Drive and Thirteenth St.	Anytime
Seventh Street	North	A point 25 metres west of Pitt Street and a point 35 metres further west	Monday to Friday 8:00 a.m. to 6:00 p.m.
Seventh Street	North	Pitt Street and Sydney Street	Anytime

3. Schedule IV (Parking Restrictions - Time Limits) of Bylaw 069, 1989 is hereby amended by adding thereto the following:

<u>COLUMN I</u>	<u>COLUMN II</u>	<u>COLUMN III</u>	<u>COLUMN IV</u>	<u>COLUMN V</u>
<u>Highway</u>	<u>Side</u>	<u>Between</u>	<u>Restricted Times of Days</u>	<u>Maximum Period Permitted</u>
Seventh St.	South	A point 25 metres west of Pitt St. and Ridley Ave.	8:00 a.m.- 6:00 p.m. Mon.-Fri.	1 hour

4. Schedule I (Stopping Restrictions) of Bylaw 069, 1989 is hereby amended by adding thereto the following:

<u>COLUMN I</u>	<u>COLUMN II</u>	<u>COLUMN III</u>	<u>COLUMN IV</u>
<u>Highway</u>	<u>Side</u>	<u>Between</u>	<u>Prohibited Times or Days</u>
Pitt Street	East	Thirteenth St. and Balmoral Avenue	Anytime
Pitt Street	West	Thirteenth St. and a point 115 metres north of Thirteenth Street	Anytime
Pitt Street	West	Jobin Avenue and Emma Avenue	Anytime

5. Schedule VIII (Parking Meter Zones - On-street) of Bylaw 069, 1989 is hereby amended by adding thereto the following:

<u>COLUMN I</u>	<u>COLUMN II</u>	<u>COLUMN III</u>	<u>COLUMN IV</u>
<u>Highway</u>	<u>Side</u>	<u>From</u>	<u>To</u>
Pitt Street	West	Thirteenth Street	Jobin Avenue

Read a First and Second time in Open Council this 11th day of June, A.D. 1990.

  
Clerk

  
Mayor

Read a Third Time, PASSED, SIGNED and SEALED in Open Council this 11th day of June, A.D. 1990.

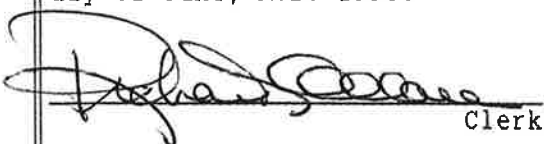
  
Clerk

  
Mayor

BYLAW NO. 126, 1990 OF THE CITY OF CORNWALL

A Bylaw to amend Bylaw No. 069, 1989  
as amended

\* \* \* \* \*

The Council of the Corporation of the City of Cornwall enacts as follows:

1. Schedule XI (Designated One-Way Streets) of Bylaw 069, 1989 is hereby amended by repealing the following:

<u>COLUMN I</u>	<u>COLUMN II</u>	<u>COLUMN III</u>
<u>Highway</u>	<u>Between</u>	<u>Directions</u>
Pitt Street	First Street and a point 61 metres south of First Street	Southbound

2. Schedule XV (Stop signs) of Bylaw 069, 1989 is hereby amended by adding thereto the following:

<u>COLUMN I</u>	<u>COLUMN II</u>
<u>Intersection</u>	<u>Facing Traffic</u>
First Street and Pitt Street	Northbound on Pitt Street

Read a First and Second time in Open Council this 10th day of September, A.D. 1990.

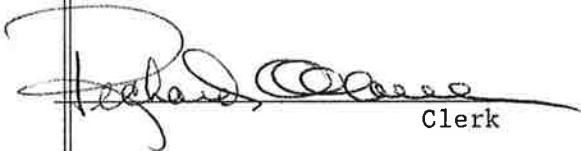
  
Clerk

  
Mayor

Read a Third time, PASSED, SIGNED and SEALED in Open Council this 10th day of September, A.D. 1990.

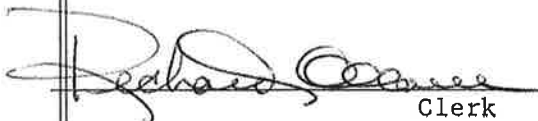
  
Clerk

  
Mayor

BY-LAW NO. 151, 1990 OF THE CITY OF CORNWALL

A bylaw to amend Bylaw No. 069, 1989  
as amended

\* \* \* \* \*

The Council of the Corporation of the City of Cornwall enacts as follows:

1. Schedule XV (Stop Signs) of Bylaw No. 069, 1989 is hereby amended by repealing the following:

<u>COLUMN I</u>	<u>COLUMN II</u>
<u>Intersection</u>	<u>Facing Traffic</u>
Aubin Ave. and Fourteenth St.	Eastbound and Westbound on Fourteenth Street
Aubin Ave. and Fifteenth St.	Eastbound and Westbound on Fifteenth Street
Aubin Ave. and Jobin Avenue	Eastbound and Westbound on Jobin Avenue

2. Schedule XIII (Prohibited Turning Movements) of Bylaw No. 069, 1989 is hereby amended by adding thereto the following:

<u>COLUMN I</u>	<u>COLUMN II</u>	<u>COLUMN III</u>	<u>COLUMN IV</u>
<u>Intersection or Portion of Highway</u>	<u>Direction</u>	<u>Movement</u>	<u>Prohibited Times or Days</u>
Thirteenth St. and Aubin Avenue	Eastbound	Left turn	Anytime
Pitt Street and Fourteenth St.	Eastbound	Right turn	Anytime
Pitt Street and Sunnyside Avenue	Westbound	Left turn	Anytime

<u>COLUMN I</u> Intersection or Portion of Highway	<u>COLUMN II</u> Direction	<u>COLUMN III</u> Movement	<u>COLUMN IV</u> Prohibited Times or Days
Pitt Street and Fifteenth St.	Eastbound	Right turn	Anytime
Pitt Street and Jobin Avenue	Eastbound	Right turn	Anytime
Pitt Street and Emma Avenue/ Balmoral Avenue	Eastbound Westbound Southbound	Right turn Left turn Straight	Anytime

Read a First and Second time in Open Council this 9th day of October, A.D. 1990.

  
Clerk

  
Mayor

Read A Third time, PASSED, SIGNED AND SEALED in Open Council this 9th day of October, A.D. 1990

  
Clerk

  
Mayor

BY-LAW NO. 158-90 OF THE CITY OF CORNWALL

A bylaw to amend By-law No. 069,1989 as amended

\* \* \* \* \*

The Council of the Corporation of the City of Cornwall enacts as follows:

1. Section 51 of By-law no. 069,1989 is hereby repealed and replaced as follows:

*For the purpose of this part:*

- (1) *"designated parking space" means a parking space designated under this part for the exclusive use of a vehicle displaying a permit in accordance with the requirements of the Highway Traffic Act and the regulations made thereunder, and this part;*
- (2) *"municipal or private property" means any open area or portion of a structure, other than a street or highway, intended for the temporary parking of vehicles and on which there are designated parking spaces, whether their use involves the payment of a fee or otherwise;*
- (3) *"permit" means a disabled person parking permit issued under the Highway Traffic Act or a permit, number plate or other marker or device issued by another jurisdiction and recognized under that Act;*

2. Section 52 of By-law No. 069,1989 is hereby repealed and replaced as follows:

- (1) *A designated parking space shall be distinctly indicated in accordance with the requirements of the Highway Traffic Act and the regulations made thereunder.*
- (2) *Every owner or operator of a public parking area who chooses to provide designated parking spaces for the exclusive use of vehicles operated by or conveying physically disabled persons, upon which is displayed a valid disabled parking permit, shall ensure that the designated parking spaces be:*
  - (a) *a minimum of three (3 m) metres in width, subject to the provisions of subsection (3);*
  - (b) *of the same length as the other parking spaces in the same public parking area;*
  - (c) *hard surfaced;*
  - (d) *level;*
  - (e) *located so as to be readily accessible to physically disabled persons, whether via ramps, depressed curbs or other means, and, where the public parking areas is intended to serve a particular building or complex, located within easy access of said building or complex;*
  - (f) *identified by signs conforming to the requirements of the Highway Traffic Act; and*

- (g) signs required under subsection (2)(f) be mounted on a permanent post with the bottom of the sign a minimum of 1.2 m and a maximum of 1.8 m above ground level with said post to be located at the end of the designated parking space at a point marking the midpoint in width of the parking space or spaces.
  - (h) kept free from obstructions, kept clear of snow, and be otherwise maintained to the same standards as all other parking spaces in the same public parking area.
- (3) Every owner or operator shall provide on one side of each designated parking space, a space one point five (1.5 m) metres in width, running the length of each designated parking space. Said space shall be marked in a manner to prevent parking thereon.
  - (4) Notwithstanding other provisions of this Section, and only until November 1, 1991, signs designating reserved stalls may display the symbols and colours as shown in Schedule XXIII to this by-law, but provided that one or both of the arrows may be deleted from the signs.
  - (5) Every owner or operator of each public parking area in which signs are located pursuant to the Highway Traffic Act and this Section shall be responsible for the procurement, installation and maintenance of said signs, and for ensuring that said signs conform with the provisions of the Highway Traffic Act and this Section.
  - (6) The driver or operator of a vehicle which displays a permit in accordance with the requirements of the Highway Traffic Act and the regulations made thereunder and this bylaw shall not be required to pay an amount in excess of the normal fee paid by other users of the same parking lots or other parking facilities to which the public has access.
3. Section 53 of By-law No. 069,1989 is hereby repealed.
4. Section 54 of By-law No. 069,1989 is hereby repealed and replaced as follows:
- (1) No person or organization shall:
    - (a) park a vehicle in a designated parking space, or
    - (b) be entitled to the benefit of an exemption under this bylaw,unless a currently valid permit has been issued to that person, organization or to a passenger being picked-up or transported in the vehicle and such permit is displayed on or in the vehicle in accordance with the requirements of the Highway Traffic Act, the regulations made thereunder and under Section 55 of this part.
  - (2) The provisions respecting the placement of a valid parking permit for the physically disabled referred to in subsection (1) hereof shall be deemed to be satisfied if a valid physically disabled permit is placed on the dashboard of the motor vehicle at the request of a Police Officer, Provincial Offences Officer, or a public parking area owner or operator.
  - (3) Neither public parking area owners nor operators shall authorize any person, other than a physically disabled person or a person conveying a physically disabled person, to park a motor vehicle in any space reserved for physically disabled persons.
  - (4) No person, other than the person to whom it was issued or a person conveying the person to whom it was issued, shall use or display a parking permit for the physically disabled issued to a physically disabled person to enjoy the privileges or avoid the restrictions set out in subsection (1) hereof.

(5) Notwithstanding the other provisions of this by-law, a Provincial Offences Officer appointed for carrying out the provisions of this by-law does not require the written complaint of the public parking area owner or operator to enforce the provisions of subsection (1) hereof.

5. Section 56 of By-law No. 069,1989 is hereby repealed.

READ a First and Second Time in Open Council this 22 day of October 1990 A.D.

  
CLERK

  
ACTING MAYOR

Read a Third and Final Time, Signed and Sealed in Open Council this 22nd day of Oct. , 1990 A.D.

  
CLERK

  
ACTING MAYOR

BYLAW NO. 176, 1990 OF THE CITY OF CORNWALL

A Bylaw to amend Bylaw No. 069, 1989  
as amended

\* \* \* \* \*

The Council of the Corporation of the City of Cornwall enacts as follows:

1. Schedule XIII (Prohibited Turning Movements) of Bylaw No. 069, 1989 is hereby amended by repealing the following:

<u>COLUMN I</u>	<u>COLUMN II</u>	<u>COLUMN III</u>	<u>COLUMN IV</u>
<u>Intersection or Portion of Highway</u>	<u>Direction</u>	<u>Movement</u>	<u>Prohibited Times or Days</u>
Thirteenth St. and Aubin Avenue	Eastbound	Left turn	Anytime
Pitt Street and Fourteenth St.	Eastbound	Right turn	Anytime
Pitt Street and Sunnyside Avenue	Westbound	Left turn	Anytime
Pitt Street and Fifteenth St.	Eastbound	Right turn	Anytime
Pitt Street and Jobin Avenue	Eastbound	Right turn	Anytime
Pitt Street and Emma Avenue/ Balmoral Avenue	Eastbound Westbound Southbound	Right turn Left turn Straight	Anytime

2. Schedule II (Parking Restrictions) of Bylaw No. 069, 1988 is hereby amended by repealing the following.

<u>COLUMN I</u>	<u>COLUMN II</u>	<u>COLUMN III</u>	<u>COLUMN IV</u>
<u>Highway</u>	<u>Side</u>	<u>Between</u>	<u>Prohibited Times or Days</u>
Aubin Avenue	East	Thirteenth St. and Emma Avenue	Anytime
Aubin Avenue	West	Thirteenth St. and Emma Avenue	Anytime

3. Schedule II (Parking Restrictions) of Bylaw No. 069, 1989 is hereby amended by adding thereto the following:

<u>COLUMN I</u>	<u>COLUMN II</u>	<u>COLUMN III</u>	<u>COLUMN IV</u>
<u>Highway</u>	<u>Side</u>	<u>Between</u>	<u>Prohibited Times or Days</u>
Aubin Avenue	East	Thirteenth St. and Fifteenth St.	Anytime
Fourteenth St.	South	Aubin Avenue and Gallinger Avenue	Anytime

Read a First and Second time in Open Council this 26th day of November, A.D. 1990.

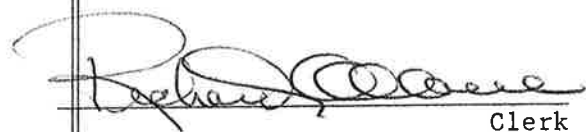
  
Clerk

  
Mayor

Read A Third time, PASSED, SIGNED AND SEALED in Open Council this 26th day of November, A.D. 1990

  
Clerk

  
Mayor



BYLAW NO. 002 , 1990 OF THE CITY OF CORNWALL

A bylaw to amend Bylaw No. 069, 1989  
as amended

\* \* \* \* \*

The Council of the Corporation of the City of Cornwall enacts as follows:

1. Schedule IX (a) (Parking Meter Zone Off Street) of Bylaw 069, 1989 is hereby amended by adding thereto the following:

<u>Column I</u>	<u>Column II</u>	<u>Column III</u>
	<u>Property</u>	<u>Description</u>
Parking lot	510 Second St. East (Cornwall General Hospital)	West side of Lawrence Avenue between Second St. and Old Orchard Ave.

2. Schedule I (Stopping Restrictions) of Bylaw 069, 1989 is hereby amended by repealing the following:

<u>Column I</u>	<u>Column II</u>	<u>Column III</u>	<u>Column IV</u>
<u>Highway</u>	<u>Side</u>	<u>Between</u>	<u>Prohibited Times or Days</u>
Pitt Street	West	Thirteenth St. and a point 115 metres north of Thirteenth Street	Anytime

3. Schedule I (Stopping Restrictions) of Bylaw 069, 1989 is hereby amended by adding thereto the following:

<u>Column I</u>	<u>Column II</u>	<u>Column III</u>	<u>Column IV</u>
<u>Highway</u>	<u>Side</u>	<u>Between</u>	<u>Prohibited Times or Days</u>
Pitt Street	West	Thirteenth St. and a point 100 metres north of Thirteenth Street	Anytime
Cumberland Street	East	Fifteenth Street and Cline Ave.	Anytime

4) Schedule XVI (Yield signs) of Bylaw 069, 1989 is hereby amended by adding thereto the following:

<u>Column I</u>	<u>Column II</u>
<u>Intersection</u>	<u>Facing Traffic</u>
McMartin Avenue and Jase Street	Eastbound on McMartin Avenue

5) Schedule II (Parking Restrictions) of Bylaw 069, 1989 is hereby amended by repealing the following:

<u>Column I</u>	<u>Column II</u>	<u>Column III</u>	<u>Column IV</u>
<u>Highway</u>	<u>Side</u>	<u>Between</u>	<u>Prohibited Times or Days</u>
Cumberland Street	East	Second Street and Emma Avenue (south)	Anytime

6. Schedule II (Parking Restrictions) of Bylaw 069, 1989 is hereby amended by adding thereto the following:

<u>Column I</u>	<u>Column II</u>	<u>Column III</u>	<u>Column IV</u>
<u>Highway</u>	<u>Side</u>	<u>Between</u>	<u>Prohibited Times or Days</u>
Cumberland Street	East	Second Street and Fifteenth St.	Anytime
Fifteenth Street	North	Churchill St. and a point 72 metres east of Lisieux St.	Anytime
Fifteenth Street	South	Cumberland St. and Notre Dame Avenue	Anytime
Cumberland Street	West	Fifteenth St. and Emma Avenue (south)	Anytime

7. Schedule VI (School Bus Loading Zones) of Bylaw 069, 1989 is hereby amended by repealing the following:

<u>Column I</u>	<u>Column II</u>	<u>Column III</u>	<u>Column IV</u>	<u>Column V</u>
<u>Highway</u>	<u>Side</u>	<u>Between</u>	<u>School or Institution</u>	<u>Prohibited Times or Days</u>
Aubin Ave.	West	Fifteenth St. and a point 105 metres south of Fifteenth St.	Sacred Heart School	Anytime

Read a First and Second time in Open Council this 14th day of January A.D. 1991.

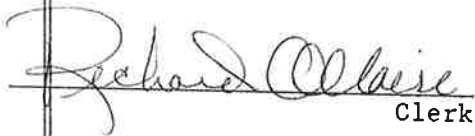
  
Clerk

  
Mayor

Read a Third time, PASSED, SIGNED and SEALED in Open Council this 14th day of January A.D. 1991.

  
Clerk

  
Mayor

BYLAW 032-1991 OF THE CITY OF CORNWALL

A bylaw to amend Bylaw No. 069, 1989  
as amended

\* \* \* \* \*

The Council of the Corporation of the City of Cornwall enacts as follows:

1. Schedule VI (School Bus Loading Zone) of Bylaw 069, 1989 is hereby amended by adding thereto the following:

<u>COLUMN I</u>	<u>COLUMN II</u>	<u>COLUMN III</u>	<u>COLUMN IV</u>	<u>COLUMN V</u>
<u>Highway</u>	<u>Side</u>	<u>Between</u>	<u>School or Institution</u>	<u>Prohibited Times or Days</u>
Cumberland St.	West	A point 75 metres north of Fifteenth Street and to a point 50 metres further north	Vincent Massey School	Anytime

Read a First and Second time in Open Council this 11th day of March, A.D. 1991.

  
Clerk

  
Mayor

Read a Third time, PASSED, SIGNED AND SEALED in Open Council this 11th day of March, A.D. 1991.

  
Clerk

  
Mayor

**BYLAW NO. 081-1991 OF THE CITY OF CORNWALL**

A bylaw to amend Bylaw No. 069, 1989  
as amended.

\* \* \* \* \*

The Council of the Corporation of the City of Cornwall enacts as follows:

1. Schedule I (Stopping Restrictions) of Bylaw 069, 1989 is hereby amended by repealing the following:

<u>COLUMN I</u>	<u>COLUMN II</u>	<u>COLUMN III</u>	<u>COLUMN IV</u>
<u>Highway</u>	<u>Side</u>	<u>Between</u>	<u>Prohibited Times or Days</u>
Second Street	North	A point 45 metres east of Pitt Street and a point 42 metres further east	Anytime

2. Schedule I (Stopping Restrictions) of Bylaw 069, 1989 is hereby amended by adding thereto the following:

<u>COLUMN I</u>	<u>COLUMN II</u>	<u>COLUMN III</u>	<u>COLUMN IV</u>
<u>Highway</u>	<u>Side</u>	<u>Between</u>	<u>Prohibited Times or Days</u>
Second Street	North	A point 45 metres east of Pitt Street and a point 42 metres further east	Monday to Saturday 8:00 a.m. to 6:00 p.m.

3. Schedule V(a) (Loading Zones) of Bylaw 069, 1989 is hereby amended by adding thereto the following:

<u>COLUMN I</u>	<u>COLUMN II</u>	<u>COLUMN III</u>	<u>COLUMN IV</u>
<u>Highway</u>	<u>Side</u>	<u>Between</u>	<u>Prohibited Times or Days</u>
Montreal Road	North	A point 18 metres west of McConnell Ave. and a point 6 metres further west	Anytime

Read a First and Second Time in Open Council this 27th day of May, A.D. 1991.

  
DEPUTY CLERK

  
MAYOR

Read a Third time, PASSED, SIGNED, AND SEALED in Open Council this 27th day of May A.D. 1991.

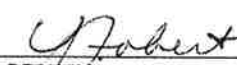
  
DEPUTY CLERK

  
MAYOR

BY-LAW NO. 124, 1991 OF THE CITY OF CORNWALL

A by-law to amend Bylaw No. 069, 1989  
as amended

\* \* \* \* \*

The Council of the Corporation of the City of Cornwall enacts as follows:

1. Schedule IV (Parking Restrictions - Time Limits) of By-law 069, 1989 is hereby amended by adding thereto the following:

<u>COLUMN I</u>	<u>COLUMN II</u>	<u>COLUMN III</u>	<u>COLUMN IV</u>	<u>COLUMN V</u>
<u>Highway</u>	<u>Side</u>	<u>Between</u>	<u>Restricted Times or Days</u>	<u>Maximum Period Permitted</u>
Park Street	North	Belmont St. and the east limit of Park Street	8:00 - 10:00 A.M. P.M. Mon-Fri.	1 hour
Park Street	South	Belmont St. and the east limit of Park Street	8:00 - 10:00 A.M. P.M. Mon-Fri.	1 hour

Read a First and Second Time in Open Council this 10th day of September, A.D. 1991.

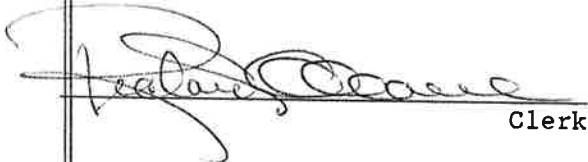
  
Clerk

  
Mayor

READ A THIRD TIME, PASSED, SIGNED AND SEALED in Open Council this 10th day of September, A.D. 1991.

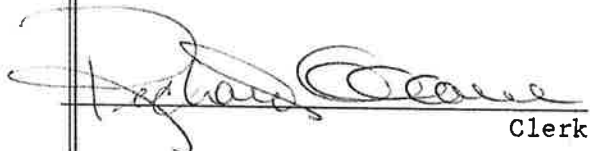
  
Clerk

  
Mayor

BYLAW NO. 142, 1991 OF THE CITY OF CORNWALL

A Bylaw to amend Bylaw No. 069, 1989  
as amended

\* \* \* \* \*

The Council of the Corporation of the City of Cornwall enacts as follows:

1. Schedule XI (Designated One-way streets) of Bylaw 069, 1989 is hereby amended by adding thereto the following:

<u>COLUMN I</u>	<u>COLUMN II</u>	<u>COLUMN III</u>
<u>Highway</u>	<u>Between</u>	<u>Direction</u>
Pitt Street	Third Street and First Street	Southbound

2. Schedule VIII (Parking Meter Zones - on-street) of Bylaw 069, 1989 is hereby amended by adding thereto the following:

<u>COLUMN I</u>	<u>COLUMN II</u>	<u>COLUMN III</u>	<u>COLUMN IV</u>
<u>Highway</u>	<u>Side</u>	<u>From</u>	<u>To</u>
Pitt Street	East	First Street	Third Street
Pitt Street	West	First Street	Third Street

3. Schedule XIV (Through Highways) of Bylaw 069, 1989 is hereby amended by adding thereto the following:

<u>COLUMN I</u>	<u>COLUMN II</u>	<u>COLUMN III</u>
<u>Highway</u>	<u>From</u>	<u>To</u>
Pitt Street	South of Third Street	North side of First Street

4. Schedule XV (Stop Signs) of Bylaw 069, 1989 is hereby amended by adding thereto the following:

<u>COLUMN I</u>	<u>COLUMN II</u>
<u>Intersection</u>	<u>Facing Traffic</u>
First Street and Pitt St.	Southbound on Pitt Street

5. Schedule XVIII (Heavy Trucks Prohibited) of Bylaw 069, 1989 is hereby amended by adding thereto the following:

<u>COLUMN I</u>	<u>COLUMN II</u>	<u>COLUMN III</u>
<u>Highway</u>	<u>Between</u>	<u>Prohibited Times/Days</u>
Pitt Street	Third Street to First Street	Anytime

6. Schedule V (A) (Loading Zones) of Bylaw 069/1989 is hereby amended by adding thereto the following:

<u>COLUMN I</u>	<u>COLUMN II</u>	<u>COLUMN III</u>	<u>COLUMN IV</u>
<u>Highway</u>	<u>Side</u>	<u>Between</u>	<u>Prohibited Times or Days</u>
Pitt Street	West	A point 35 metres north of First St. and a point 35 metres further north	7:00 a.m. - 10:00 a.m. Mon. - Sat.
Pitt Street	West	A point 10 metres south of Third St. and a point 30 metres further south	7:00 a.m. - 10:00 a.m. Mon. - Sat.
Pitt Street	West	A point 35 metres south of First St. and a point 15 metres further south	Anytime

7. Schedule XII (Designated Traffic Lanes) of Bylaw 069, 1989 is hereby amended by adding thereto the following:

<u>COLUMN I</u>	<u>COLUMN II</u>	<u>COLUMN III</u>	<u>COLUMN IV</u>	<u>COLUMN V</u>
<u>Highway</u>	<u>Between</u>	<u>Lane</u>	<u>Direction</u>	<u>Times/Days</u>
Pitt St.	Third St. and a point 50 metres north	First Lane from east curb	Southbound	Anytime
Pitt St.	Third St. and a point 50 metres north	Second lane from east curb	Southbound & southbound right-turn	Anytime
Pitt St.	Third St. and a point 50 metres north	Third lane from east curb	Southbound right-turn	Anytime
Pitt St.	First St. and a point 50 metres north	First Lane from east curb	Southbound left-turn	Anytime
Pitt St.	First St. and a point 50 metres north	Second Lane from east curb	Southbound	Anytime

Read a First and Second time in Open Council this 15th day of October, A.D. 1991.

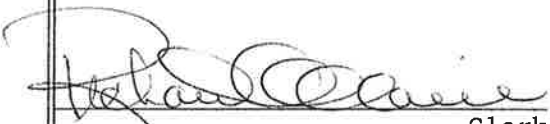
  
Clerk

  
Mayor

Read a Third time, PASSED, SIGNED and SEALED in Open Council this 15th day of October, A.D. 1991.

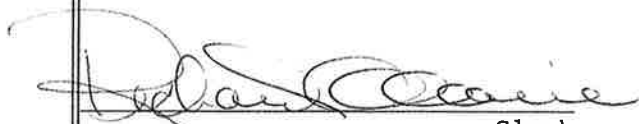
  
Clerk

  
Mayor

BYLAW NO. 143-1991 OF THE CITY OF CORNWALL

A bylaw to amend Bylaw No. 069, 1989  
as amended

\* \* \* \* \*

The Council of the Corporation of the City of Cornwall enacts as follows:

1. Schedule XXII (Pedestrian Crossovers) of Bylaw 069, 1989 is hereby amended by adding thereto the following:

<u>COLUMN I</u>	<u>COLUMN II</u>
<u>Highway</u>	<u>Intersection or Location</u>
McConnell Ave.	south of Ridgewood Drive

2. Schedule IX (a) (Parking Meter Zones - Off-street) of Bylaw 069, 1989 is hereby amended by adding thereto the following:

<u>COLUMN I</u>	<u>COLUMN II</u>	<u>COLUMN III</u>
	<u>Property</u>	<u>Description</u>
Parking Lot	840 McConnell Ave. (Hotel Dieu Hospital)	East side of McConnell Ave.

3. Section 21 of Bylaw 069, 1989 is hereby amended by adding thereto the following:

21 (4) Where a "Pay-and-Display" machine has been installed under the authority of this bylaw, no person shall park a vehicle, or permit a vehicle to remain parked in a parking meter space within a parking lot unless the owner, operator or driver of the said vehicle, upon entering the said parking space:

(a) immediately deposits the required money in the "Pay-and-Display" machine controlling the parking meter space as indicated by signs;

(b) displays the valid and unexpired ticket issued by the "Pay-and-Display" machine clearly in sight on the left side of the front dashboard of the vehicle parked in the said parking meter space.

(c) the ticket referred to in sub-section (b) above shall clearly show the parking lot name, date, and expiry time.

22 (4) Where a "Pay-and-Display" machine has been installed under the authority of this bylaw, no person shall park a vehicle, or permit a vehicle to remain parked in a parking meter space within a parking lot on which an expired ticket is displayed.

Read a First and Second Time in Open Council this 28th day of October, A.D. 1991.

  
Clerk

  
Mayor

Read a Third time, PASSED, SIGNED, AND SEALED in Open Council this 28th day of October, A.D. 1991.

  
Clerk

  
Mayor



BY-LAW NO.023-1992, OF THE CITY OF CORNWALL

A by-law to amend by-law 069-1989  
the Traffic and Parking by-law

\* \* \* \* \*

WHEREAS the Corporation of the City of Cornwall appoints various people to act as Municipal By-law Enforcement Officers for the purpose of enforcing the Traffic and Parking by-law.

AND WHEREAS it is deemed necessary to amend section 1, subsection 33 under definitions and interpretation defining "Provincial Offences Officer".

NOW THEREFORE the Council of The Corporation of the City of Cornwall enacts as follows:

1. That by-law 069-1989 section 1, subsection 33 of the Definitions and Interpretation clause be amended to read as follows:  
"Provincial Offences Officer shall mean a person who is duly appointed by the Council of the Corporation for the purpose of enforcing the provisions of the Corporation's by-laws."

READ a First and Second Time in Open Council this 24th day of February, 1992.

  
CLERK

  
MAYOR

Read a Third and Final Time, Signed and Sealed in Open Council this 24th day of February, 1992 A.D.

  
CLERK

  
MAYOR

BY-LAW NO. 074 -- 1992 OF THE CITY OF CORNWALL

A by-law to amend By-law No. 069, 1989  
as amended

\* \* \* \* \*

The Council of the Corporation of the City of Cornwall enacts as follows:

1. Schedule XV (Stop Signs) of By-law 069, 1989 is hereby amended by adding thereto the following:

COLUMN I

COLUMN II

Intersection

Facing Traffic

Eighth Street and  
Adolphus Street

Westbound on Eighth Street

Read a First and Second time in Open Council this 8th day of June, A.D. 1992.

  
Clerk

  
Mayor

Read a Third time, PASSED, SIGNED and SEALED in Open Council this 8th day of June, A.D. 1992.

  
Clerk

  
Mayor

BY-LAW NO.085- 1992 OF THE CITY OF CORNWALL

A By-law to amend By-law No. 069, 1989  
as amended

\* \* \* \* \*

The Council of the Corporation of the City of Cornwall enacts as follows:

1. Schedule XII (Designated Traffic Lanes) of By-law No. 069, 1989 is hereby amended by repealing the following:

<u>COLUMN I</u>	<u>COLUMN II</u>	<u>COLUMN III</u>	<u>COLUMN IV</u>	<u>COLUMN V</u>
<u>Highway</u>	<u>Between</u>	<u>Lane</u>	<u>Direction</u>	<u>Times/Day</u>
Sydney St.	Lourdes Cresc. and 13th St.	Second lane from west curb	Northbound left-turn & northbound	Anytime

2. Schedule XII (Designated Traffic Lanes) of By-law No. 069, 1989 is hereby amended by adding thereto the following:

<u>COLUMN I</u>	<u>COLUMN II</u>	<u>COLUMN III</u>	<u>COLUMN IV</u>	<u>COLUMN V</u>
<u>Highway</u>	<u>Between</u>	<u>Lane</u>	<u>Direction</u>	<u>Times/Day</u>
Sydney St.	Lourdes Cresc. and 13th St.	Second lane from west curb	Northbound left-turn	Anytime

3. Schedule XIII (Prohibited Turning Movements) of By-law No. 069, 1989 is hereby amended by adding thereto the following:

<u>COLUMN I</u>	<u>COLUMN II</u>	<u>COLUMN III</u>	<u>COLUMN IV</u>
<u>Intersection or Portion of Highway</u>	<u>Direction</u>	<u>Prohibited Movements</u>	<u>Times or Days</u>
13th St. and Reneal Street	Eastbound	Left-turn	Anytime
13th St. and Reneal Street	Southbound	Left-turn	Anytime

4. Schedule II (Parking Restrictions) of By-law No. 069, 1989 is hereby amended by adding thereto the following:

<u>COLUMN I</u>	<u>COLUMN II</u>	<u>COLUMN III</u>	<u>COLUMN IV</u>
<u>Highway</u>	<u>Side</u>	<u>Between</u>	<u>Prohibited Times or Days</u>
Ridgewood Dr.	South	Marlborough St. & McConnell Ave.	Anytime
Valecrest Dr. (East)	East	Ridgewood Dr. & Valecrest Dr. (South)	Anytime
Frontenac St.	West	Second St. and King Street	Anytime
Frontenac St.	East	Second St. and King Street	Anytime
King Street	North	Frontenac St. & Young Street	Anytime
King Street	South	Frontenac St. & Young Street	Anytime
Young Street	West	King St. and Second Street	Anytime
Young Street	East	King St. and Second Street	Anytime
Amelia Street	West	Third St. and Fourth Street	8:00-6:00 A.M. P.M. Mon.- Fri.

5. Schedule IV (Parking Restrictions - Time Limits) of By-law No. 069, 1989 is hereby amended by adding thereto the following:

<u>COLUMN I</u>	<u>COLUMN II</u>	<u>COLUMN III</u>	<u>COLUMN IV</u>	<u>COLUMN V</u>
<u>Highway</u>	<u>Side</u>	<u>Between</u>	<u>Restricted Times/Days</u>	<u>Maximum Period Permitted</u>
Ridgewood Drive	North	Marlborough Street and McConnell Ave.	8:00-6:00 A.M. P.M. Mon.- Fri.	2 hours
Valecrest Dr. (East)	West	Ridgewood Dr. and Valecrest Drive (South)	8:00-6:00 A.M. P.M. Mon.- Fri.	2 hours

Read a First and Second Time in Open Council this 13th day of July,  
A.D. 1992.

  
Clerk

  
Mayor

Read a Third Time, PASSED, SIGNED, and SEALED in Open Council this  
13th day of July, A.D. 1992.

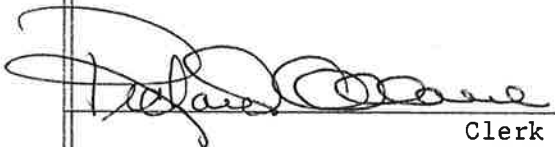
  
Clerk

  
Mayor

BY-LAW NO. 94, 1992 OF THE CITY OF CORNWALL

A By-law to amend By-law No 069, 1989  
as amended

\* \* \* \* \*

The Council of the Corporation of the City of Cornwall enacts as follows:

1. Schedule XVI (Yield Signs) of By-law No. 069, 1989 is hereby amended by repealing the following:

COLUMN I

COLUMN II

Intersection

Facing Traffic

Guy Street and  
Lasalle Road

Northbound on Guy Street

2. Schedule XV (Stop Signs) of By-law No. 069, 1989 is hereby amended by adding thereto the following:

COLUMN I

COLUMN II

Intersection

Facing Traffic

Guy Street and  
Lasalle Road

Northbound on Guy Street

Read a First and Second time in Open Council this 13th day of July, A.D. 1992.

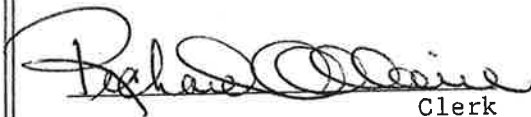
  
Clerk

  
Mayor

Read a Third time, PASSED, SIGNED and SEALED in Open Council this 13th day of July, A.D. 1992.

  
Clerk

  
Mayor

BY-LAW NO.096, 1992 OF THE CITY OF CORNWALL

A By-law to amend By-law No 069, 1989  
as amended

\* \* \* \* \*

The Council of the Corporation of the City of Cornwall enacts as follows:

1. Schedule XIV (Through Highways) of By-law No. 069, 1989 is hereby amended by repealing the following:

<u>COLUMN I</u>	<u>COLUMN II</u>	<u>COLUMN III</u>
<u>Highway</u>	<u>From</u>	<u>To</u>
Lynwood Drive	North side of Second Street	North limit of Lynwood Dr.

2. Schedule XIV (Through Highways) of By-law No. 069, 1989 is hereby amended by adding thereto the following:

<u>COLUMN I</u>	<u>COLUMN II</u>	<u>COLUMN III</u>
<u>Highway</u>	<u>From</u>	<u>To</u>
Lynwood Drive	North side of Second Street	South side of Holy Cross Blvd.

3. Schedule XV (Stop Signs) of By-law No. 069, 1989 is hereby amended by adding thereto the following:

<u>COLUMN I</u>	<u>COLUMN II</u>
Holy Cross Blvd. and Lynwood Drive	Eastbound & westbound on Holy Cross Boulevard Northbound & southbound on Lynwood Drive
Holy Cross Blvd. and Dean Dr./Paulette St.	Eastbound & westbound on Holy Cross Boulevard Southbound on Paulette St.
Glengarry Boulevard and Lochiel Street	Eastbound & westbound on Lochiel Street

Read a First and Second time in Open Council this 13th day of July, A.D. 1992.

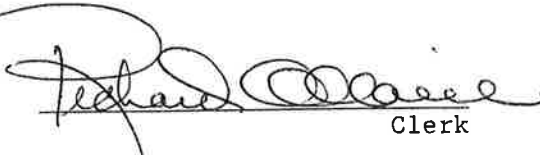
  
Clerk

  
Mayor

Read a Third time, PASSED, SIGNED and SEALED in Open Council this 13th day of July, A.D. 1992.

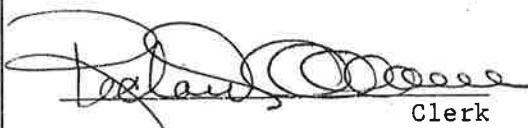
  
Clerk

  
Mayor

BY-LAW NO.106, 1992 OF THE CITY OF CORNWALL

A by-law to amend By-law No. 069, 1989  
as amended

\* \* \* \* \*

The Council of the Corporation of the City of Cornwall enacts as follows:

1. Schedule XII (Designated Traffic Lanes) of By-law No. 069, 1989 is hereby amended by adding thereto the following:

<u>COLUMN I</u>	<u>COLUMN II</u>	<u>COLUMN III</u>	<u>COLUMN IV</u>	<u>COLUMN V</u>
<u>Highway</u>	<u>Between</u>	<u>Lane</u>	<u>Direction</u>	<u>Times/Days</u>
Pitt Street	Ninth Street and a point 50 metres north	First lane from west curb	Southbound right-turn	Anytime
Ninth Street	Brookdale Avenue and a point 50 metres east	First lane from north curb	Westbound right-turn	Anytime

2. Schedule XIII (Prohibited Turning Movements) of By-law No. 069, 1989 is hereby amended by adding thereto the following:

<u>COLUMN I</u>	<u>COLUMN II</u>	<u>COLUMN III</u>	<u>COLUMN IV</u>
<u>Intersections or Portion of Highway</u>	<u>Direction</u>	<u>Prohibited Movement</u>	<u>Times/Days</u>
Canadian Tire/ Loblaws and Ninth Street	Southbound	Left-turn and straight	Anytime

3. Schedule XVI (Yield signs) of By-law No. 069, 1989 is hereby amended by adding thereto the following:

<u>COLUMN I</u>	<u>COLUMN II</u>
<u>Intersection</u>	<u>Facing Traffic</u>
Thirteenth Street and Pitt Street	Westbound on Thirteenth Street turning north

4. Schedule I (Stopping Restrictions) of By-law No. 069, 1989 is hereby amended by adding thereto the following:

<u>COLUMN I</u>	<u>COLUMN II</u>	<u>COLUMN III</u>	<u>COLUMN IV</u>
<u>Highway</u>	<u>Side</u>	<u>Between</u>	<u>Prohibited Times/Days</u>
Sydney Street	West	Ninth St. and Eleventh Street	Anytime

5. Schedule VI (School Bus Loading Zone) of By-law No. 069, 1989 is hereby amended by repealing the following:

<u>COLUMN I</u>	<u>COLUMN II</u>	<u>COLUMN III</u>	<u>COLUMN IV</u>	<u>COLUMN V</u>
<u>Highway</u>	<u>Side</u>	<u>Between</u>	<u>School or Institution</u>	<u>Prohibited Times/Days</u>
Fifteenth St.	North	Lisieux St. and a point 72 metres east of Lisieux Street	Ecole Notre Dame Sr.	Anytime

6. Schedule II (Parking Restrictions) of By-law No. 069, 1989 is hereby amended by adding thereto the following:

<u>COLUMN I</u>	<u>COLUMN II</u>	<u>COLUMN III</u>	<u>COLUMN IV</u>
<u>Highway</u>	<u>Side</u>	<u>Between</u>	<u>Prohibited Times/Days</u>
Fifteenth Street	North	Cumberland St. and west limit of Fifteenth St.	Anytime
Killarney Avenue	West	Seventh Street and Eighth St.	Anytime
Leonia Street	West	Montreal Road and Easton Ave.	Anytime

Read a First and Second time in Open Council this 10th day of August, A.D. 1992.

  
Clerk

  
Mayor

Read a Third time, PASSED, SIGNED and SEALED in Open Council this 10th, day of August, A.D. 1992,

  
Clerk

  
Mayor

BY-LAW NO. 133, 1992 OF THE CITY OF CORNWALL

A by-law to amend By-law No. 069, 1989  
as amended

\* \* \* \* \*

The Council of the Corporation of the City of Cornwall enacts as follows:

1. Schedule 1 (Stopping Restrictions) of By-law No. 069, 1989 is hereby amended by adding thereto the following:

<u>COLUMN 1</u>	<u>COLUMN II</u>	<u>COLUMN III</u>	<u>COLUMN IV</u>
<u>Highway</u>	<u>Side</u>	<u>Between</u>	<u>Prohibited Times or Days</u>
Pitt Street	West	A point 42 metres metres north of Fifteenth Street and a point 40 metres further north	Anytime
Sydney St.	West	Water Street and Thirteenth Street	Anytime

2. Schedule XIII (Prohibited Turning Movements) of By-law No. 069, 1989 is hereby amended by repealing the following:

<u>COLUMN 1</u>	<u>COLUMN II</u>	<u>COLUMN III</u>	<u>COLUMN IV</u>
<u>Intersection or portion of Highway</u>	<u>Direction</u>	<u>Prohibited Movement</u>	<u>Times or Days</u>
Pitt St. from a point 60 metres south of First Street to a point 75 metres south of First Street	Southbound	Left turn	Anytime

3. Schedule II (Parking Restrictions) of By-law No. 069, 1989 is hereby amended by repealing the following:

<u>COLUMN 1</u>	<u>COLUMN II</u>	<u>COLUMN III</u>	<u>COLUMN IV</u>
<u>Highway</u>	<u>Side</u>	<u>Between</u>	<u>Prohibited Times or Days</u>
Fifteenth St.	South	Pitt Street and Cumberland Street	Anytime
Fifteenth St.	South	Cumberland Street and west limit of Fifteenth Street	Anytime

4. Schedule II (Parking Restrictions) of By-law No. 069, 1989 is hereby amended by adding thereto the following:

<u>COLUMN 1</u>	<u>COLUMN II</u>	<u>COLUMN III</u>	<u>COLUMN IV</u>
<u>Highway</u>	<u>Side</u>	<u>Between</u>	<u>Prohibited Times or Days</u>
Fifteenth St	South	Pitt Street and Churchill Street.	Anytime
Fifteenth St.	South	Churchill St. and Notre Dame St.	8:00 - 6:00 A.M. P.M. Mon. - Fri.
Cumberland St.	West	Thirteenth Street and Fifteenth St.	2:00 - 4:00 P.M. P.M. Mon. - Fri.
McDonald Ave.	North	Bedford St. and Cumberland Street	Anytime
Lawrence Ave	West	Old Orchard Avenue and a point 60 metres south of Old Orchard Avenue	Anytime

5. Schedule IV (Parking Restrictions - Time Limits) of Bylaw No. 069, 1989 is hereby amended by adding thereto the following:

<u>COLUMN I</u>	<u>COLUMN II</u>	<u>COLUMN III</u>	<u>COLUMN IV</u>	<u>COLUMN V</u>
<u>Highway</u>	<u>Side</u>	<u>Between</u>	<u>Restricted Times or Days</u>	<u>Maximum Period Permitted</u>
Amelia St.	West	First St. and a point 97 metres south of First St.	8:00 - 6:00 A.M. P.M. Mon. - Fri.	3 hours

<u>COLUMN I</u>	<u>COLUMN II</u>	<u>COLUMN III</u>	<u>COLUMN IV</u>	<u>COLUMN V</u>
<u>Highway</u>	<u>Side</u>	<u>Between</u>	<u>Restricted Times or Days</u>	<u>Maximum Period Permitted</u>
Lawrence Avenue	West	A point 60 metres south of Old Orchard Avenue and Second St.	8:00 - 6:00 A.M. P.M. Mon. - Fri.	2 hours
Lawrence Avenue	West	First St. and Second Street	8:00 - 6:00 A.M. P.M. Mon. - Fri.	2 hours

6. Schedule XVIII (Heavy Trucks Prohibited) of Bylaw No. 069, 1989 is hereby amended by adding thereto the following:

<u>COLUMN I</u>	<u>COLUMN II</u>	<u>COLUMN III</u>
<u>Highway</u>	<u>Between</u>	<u>Times/Days</u>
Billington Dr.	Second St. and Concorde Avenue	Anytime
Walton St.	Dunbar Ave. and Billington Dr.	Anytime
Tollgate Rd.	Vincent Massey Dr. and Power Dam Drive	Anytime

7. Schedule V (Loading Zones) of By-law No. 069, 1989 is hereby amended by adding thereto the following:

Schedule V (D) (Loading Zones - Disabled Persons) of By-law No. 069, 1989 is hereby amended by adding thereto the following:

<u>COLUMN 1</u>	<u>COLUMN II</u>	<u>COLUMN III</u>	<u>COLUMN IV</u>
<u>Highway</u>	<u>Side</u>	<u>Between</u>	<u>Prohibited Times/Days</u>

Schedule V(C) (Loading Zones - Authorized Signs) - attached page.

8. Schedule V (D) (Loading Zones - Disabled Persons) of By-law No. 069, 1989 is hereby amended by adding thereto the following:

<u>COLUMN 1</u>	<u>COLUMN II</u>	<u>COLUMN III</u>	<u>COLUMN IV</u>
<u>Highway</u>	<u>Side</u>	<u>Between</u>	<u>Times or Days</u>
Cumberland Street	East	A point 144 metres north of Fifteenth Street and a point 75 metres further north	Anytime

9. Section 16 of By-law No. 069, 1989 is hereby repealed and replaced as follows:

Loading Zones

- 16.(1) (a) Where authorized signs as set out in Schedule V (b) of this by-law are displayed, no person shall stop or park any vehicle or permit a vehicle to remain stopped or parked, other than a commercial motor vehicle, in any Loading Zone on any highway, at the side and between the limits set out respectively in columns 1, 2 and 3 of Schedule V (d) of this by-law during the days or times set out in Column 4 of the said Schedule.
- (b) Where authorized signs as set out in Schedule V (c) of this by-law are displayed, no person shall stop or park any vehicle or permit a vehicle to remain stopped or parked, other than a vehicle operated by or conveying a physically disabled person, upon which is displayed a valid disabled parking permit, in any physically disabled persons Loading Zone on any highway, at the side and between the limits set out respectively in Columns 1, 2 and 3 of Schedule V (d) of this by-law during the days or times set out in Column 4 of the said schedules.
- (2) (a) Where authorized signs to that effect are displayed, no person shall stop or park any commercial motor vehicle in any Loading Zone on any highway, at the side, and between the limits set out respectively in Columns 1, 2 and 3 of Schedule V (a) to this by-law for any purpose other than for the expeditious unloading and delivery or pick-up and loading of materials, passengers or goods during the days or times set out in Column 4 of the said schedule. In no case shall the stop exceed fifteen (15) minutes.

- (b) When authorized signs to that effect are displayed, no person shall stop or park any vehicle operated by or conveying a physically disabled persons, upon which is displayed a valid disabled parking permit in any Physically Disabled Persons Loading Zone on any highway, at the side and between the limits set out respectively in Columns 1, 2 and 3 of Schedule V (d) to this by-law for any purpose other than for the expeditious unloading or pick-up of Disabled Persons during the days or times set out in Column 4 of the said schedule. In no case shall the stop exceed fifteen (15) minutes.

Read a FIRST and SECOND Time in Open Council this 9th day of November, A.D. 1992.

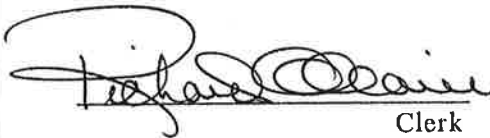
  
Clerk

  
Mayor

Read a THIRD time, PASSED, SIGNED and SEALED in Open Council this 9th day of November, A.D. 1992.

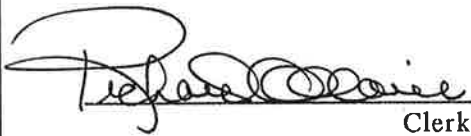
  
Clerk

  
Mayor

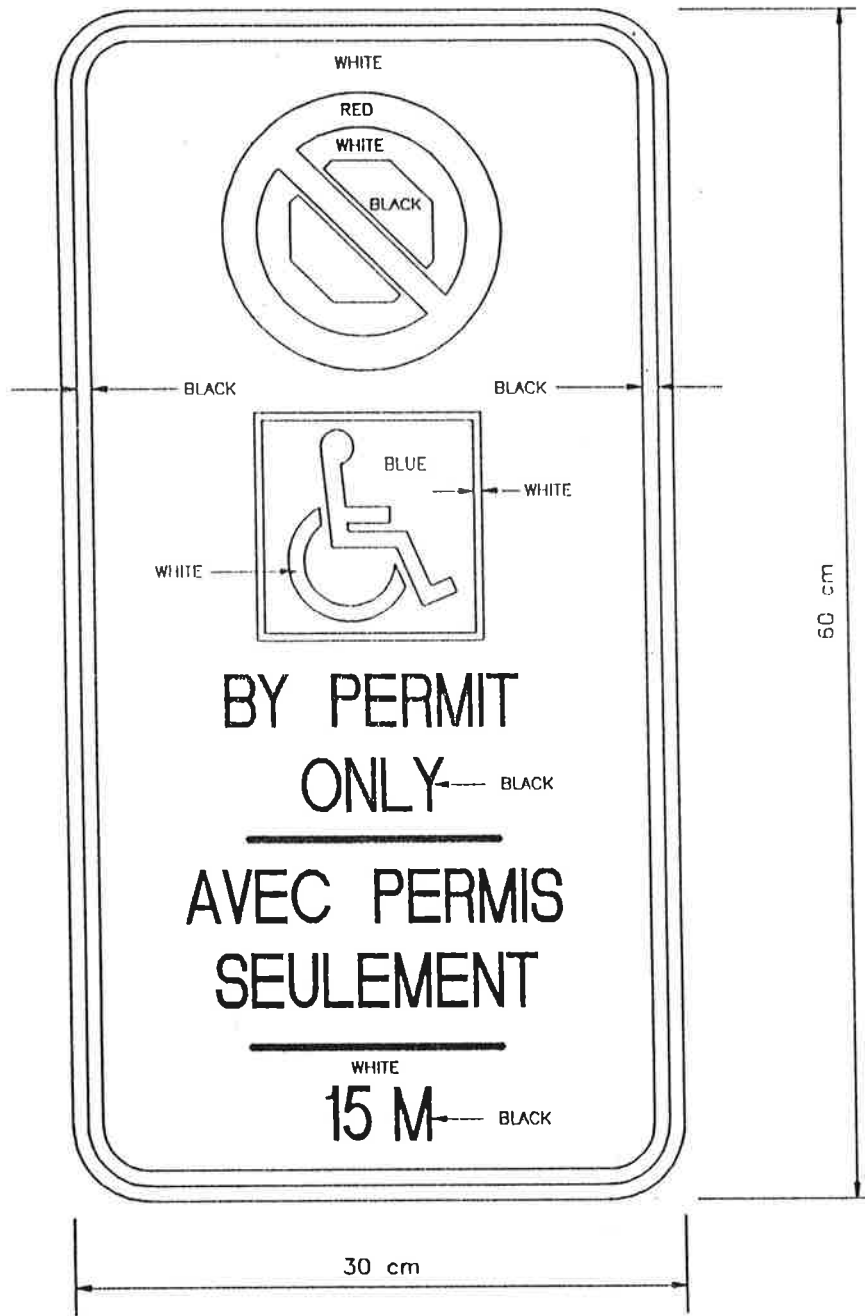

CITY OF CORNWALL ENGINEERING DEPARTMENT	DRAWN BY: A.J.A.
	DATE: 92-10-30
SCHEDULE V (C) LOADING ZONES FOR DISABLED AUTHORIZED SIGN	SCALE: N.T.S.

BY-LAW NO. 135, 1992 OF THE CITY OF CORNWALL

**A by-law to amend By-law No. 069, 1989  
as amended**

\* \* \* \* \*

The Council of the Corporation of the City of Cornwall enacts as follows:

1. Schedule XXI (Prohibited Pedestrian Crossing) of By-law No. 069, 1989 is hereby amended by repealing the following:

<u>COLUMN I</u>	<u>COLUMN II</u>	<u>COLUMN III</u>
<u>Highway</u>	<u>Location</u>	<u>Prohibited Crossing</u>
Brookdale Avenue	Fourteenth Street	North Crosswalk

2. The provisions of this by-law effecting traffic on highways designated as Connecting Links pursuant to the Public Transportation and Highway Improvement Act shall not become effective until approved by the Ontario Ministry of Transportation.

Read a FIRST and SECOND Time in Open Council this 9th day of November, A.D. 1992.

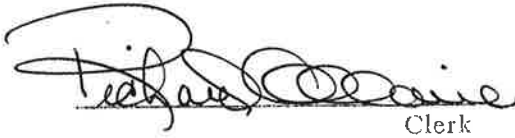
  
Clerk

  
Mayor

Read a THIRD time, PASSED, SIGNED and SEALED in Open Council this 9th day of November, A.D. 1992.

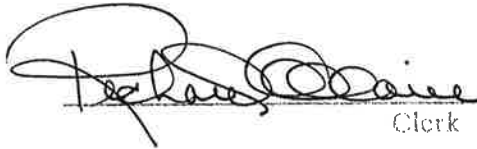
  
Clerk

  
Mayor

BY-LAW NO. 139-1992 OF THE CITY OF CORNWALL

A by-law to amend By-law No. 069-1989  
as amended

\* \* \* \* \*

The Council of the Corporation of the City of Cornwall enacts as follows:

1. Schedule II (Parking Restrictions) of By-law No. 069-1989 is hereby amended by adding thereto the following:

<u>COLUMN I</u>	<u>COLUMN II</u>	<u>COLUMN III</u>	<u>COLUMN IV</u>
<u>Highway</u>	<u>Side</u>	<u>Between</u>	<u>Prohibited Times or Days</u>
Aubin Avenue	West	A point 30 metres north of Fifteenth Street and a point 50 metres further north	Anytime
Aubin Avenue	East	Fifteenth Street and a point 60 metres north of Fifteenth Street	Anytime
Reneal Street	West	A point 122 metres north of Sunnyside Avenue and a point 50 metres further north	Anytime
Reneal Street	East	A point 102 metres north of Sunnyside Avenue and a point 50 metres further north	Anytime
St. Michel Ave.	West	A point 101 metres north of Sunnyside Avenue and a point 50 metres further north	Anytime
St. Michel Ave.	East	A point 81 metres north of Sunnyside Avenue and a point 50 metres further north	Anytime

Read a First and Second time in Open Council this 23rd day of November, A.D. 1992.

  
Clerk

  
Mayor

Read a Third time, PASSED, SIGNED and SEALED in Open Council this 23rd day of November, A.D. 1992.

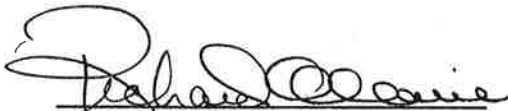
  
Clerk

  
Mayor

BY-LAW NO.158-1992 OF THE CITY OF CORNWALL

A By-law to amend By-law No. 069, 1989  
as amended

\* \* \* \* \*

The Council of the Corporation of the City of Cornwall enacts as follows:

1. Schedule II (Parking Restrictions) of By-law No. 069, 1989 is hereby amended by repealing the following:

<u>COLUMN I</u>	<u>COLUMN II</u>	<u>COLUMN III</u>	<u>COLUMN IV</u>
<u>Highway</u>	<u>Side</u>	<u>Between</u>	<u>Prohibited Times/Days</u>
Glengarry Blvd.	East	Second Street and Lochiel Street	Anytime

2. Schedule II (Parking Restrictions) of By-law No. 069, 1989 is hereby amended by adding thereto the following:

<u>COLUMN I</u>	<u>COLUMN II</u>	<u>COLUMN III</u>	<u>COLUMN IV</u>
<u>Highway</u>	<u>Side</u>	<u>Between</u>	<u>Prohibited Times/Days</u>
Glengarry Blvd.	East	Second Street and a point 50 metres north of Champlain Drive	Anytime
Glengarry Blvd.	East	From a point 50 metres south of Dundas Crescent (south) and Lochiel Street	Anytime
Glengarry Blvd.	West	Second Street and Dundas Crescent (south)	Anytime

Read a First and Second time in Open Council this 14th day of December, A.D. 1992.

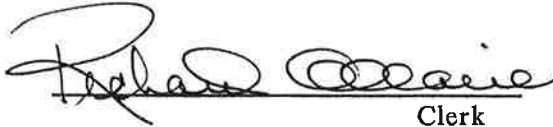
  
Clerk

  
Mayor

Read a Third Time, PASSED, SIGNED and SEALED in Open Council this 14th day of December, A.D. 1992.

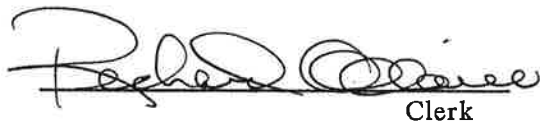
  
Clerk

  
Mayor



BY-LAW NO. 02, 1993 OF THE CITY OF CORNWALL

A by-law to amend By-law No. 069, 1989 as amended

\* \* \* \* \*

The Council of the Corporation of the City of Cornwall enacts as follows:

1. Schedule IV (Parking Restrictions- Time Limits) of By-law No. 069, 1989 is hereby amended by adding thereto the following:

<u>COLUMN I</u>	<u>COLUMN II</u>	<u>COLUMN III</u>	<u>COLUMN IV</u>	<u>COLUMN V</u>
<u>Highway</u>	<u>Side</u>	<u>Between</u>	<u>Restricted Times or Days</u>	<u>Maximum Period Permitted</u>
Old Orchard Ave.	South	Lawrence Ave. and Baldwin Ave.	8:00am - 6:00pm Monday to Friday	2 hours

READ a First and Second Time in Open Council this 11th day of January, 1993.

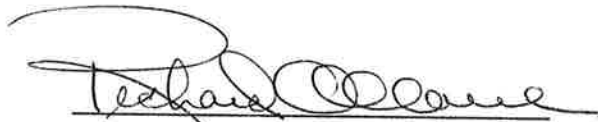

CLERK



MAYOR

READ a Third and Final Time, Signed and Sealed in Open Council this 11th day of January, 1993.

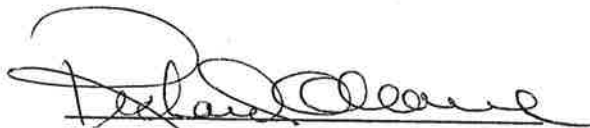

CLERK



MAYOR

**BY-LAW NO. 074-1993 OF THE CITY OF CORNWALL**

*A by-law to amend By-law No. 069-1989  
as amended*

\* \* \* \* \*

The Council of the Corporation of the City of Cornwall enacts as follows:

1. By-law 069-1989 is hereby amended by adding thereto the following:

1. (40a) "Skateboard" means a platform with rollers rollers or wheels used by a person or persons for transportation or play.

45. (3) The authorized sign "~~No Skateboarding~~" shall be as shown in Schedule XXVI.

*Repealed  
BYLAW 9-98*

*(4)(3)* No person shall operate a skateboard on any roadway, sidewalk or boulevard on any highway described in Schedule XXVII of this bylaw.

*(8)(4)* No person shall operate a skateboard on the turf, sward, footpath or any other ground in any public park or other City property as described in Schedule XXVIII of this bylaw.

2. By-law No. 069-1989 is hereby amended by adding thereto Schedule XXVI (No Skateboarding Sign).

*repealed  
9/98*

3. By-law No. 069-1989 is hereby amended by adding thereto Schedule XXVII (Skateboard Prohibitions - Highways):

<u>COLUMN I</u>	<u>COLUMN II</u>	<u>COLUMN III</u>
<u>Highway</u>	<u>Between</u>	<u>Times/Days</u>

4. By-law No. 069-1989 is hereby amended by adding thereto Schedule XXVIII (Skateboard Prohibitions - Parks and City Property):

<u>COLUMN I</u>	<u>COLUMN II</u>	<u>COLUMN III</u>
<u>Property</u>	<u>Description</u>	<u>Times/Days</u>

5. Schedule XXVII (Skateboard Prohibitions - Highways) of By-law No. 069-1989 is hereby amended by adding thereto the following:

<u>COLUMN I</u>	<u>COLUMN II</u>	<u>COLUMN III</u>
<u>Highway</u>	<u>Between</u>	<u>Times/Days</u>
Pitt Street	Fourth St. and Water Street	Anytime
First Street	Augustus St. and Sydney Street	Anytime
Second Street	Augustus St. and Sydney Street	Anytime
Third Street	Augustus St. and Sydney Street	Anytime
Montreal Road	Marlborough St. and Alice Street	Anytime
Albert Street	Montreal Road and Lennox Street	Anytime
Lawrence Avenue	Montreal Road and First Street	Anytime
Baldwin Avenue	Montreal Road and Chevrier Avenue	Anytime
Arthur Street	Montreal Road and Lennox Street	Anytime
Edward Street	Montreal Road and Lennox Street	Anytime
McConnell Avenue	Walton Street and Lennox Street	Anytime
Prince Arthur St.	Walton St. and Prince Albert St.	Anytime
Louisa Street	Walton Street and Prince Albert St.	Anytime

6. Schedule XXVIII (Skateboard Prohibitions - Parks and City Property) of By-law No. 069-1989 is hereby amended by adding thereto the following:

<u>COLUMN I</u>	<u>COLUMN II</u>	<u>COLUMN III</u>
<u>Property</u>	<u>Description</u>	<u>Times/Days</u>
City Hall	360 Pitt Street	Anytime
Justice Building	340 Pitt Street	Anytime
City Hall and Justice Building Parking Area	340 Pitt Street, and 360 Pitt Street	Anytime
Parkette	123 Pitt Street	Anytime
Vogue Lot	512 Montreal Rd.	Anytime
B.P. Lot	342 Montreal Rd.	Anytime
Port Theatre (Emard) Lot	Corner of Montreal Road and Lawrence Avenue	Anytime
Justice/Municipal Lot	Corner of Third St. and Augustus St.	Anytime
Zeller's (Second St.) Lot	Mid-block on Second Street Augustus St. to Pitt St. - south side	Anytime
Cornwallis (Second St.) Lot	Mid-block on Second Street Augustus St. to Pitt St. - south side West of Zellers lot	Anytime
First & Pitt Lot	Corner of First St. and Pitt Street	Anytime
Hart & Carra Lot	Mid-block on Pitt Street between Second St. and First Street - East side	Anytime

<u>COLUMN I</u>	<u>COLUMN II</u>	<u>COLUMN III</u>
<u>Property</u>	<u>Description</u>	<u>Times/Days</u>
Warrington/Brown (Backstreets) Lot	Centre of Block First St. to Second Street and Pitt St. to Sydney Street	Anytime
Second & Sydney Lot	Corner of Second St. and Sydney St.	Anytime
Third Street East Lot	Mid-block on Third Street between Sydney St. and Pitt Street - south side	Anytime

Read a First and Second time in Open Council this 14th day of June,  
A.D. 1993.

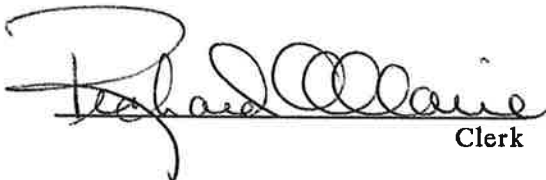
  
Clerk

  
Mayor

Read a Third Time, **PASSED, SIGNED and SEALED** in Open Council this  
14th day of June, A.D. 1993.

  
Clerk

  
Mayor

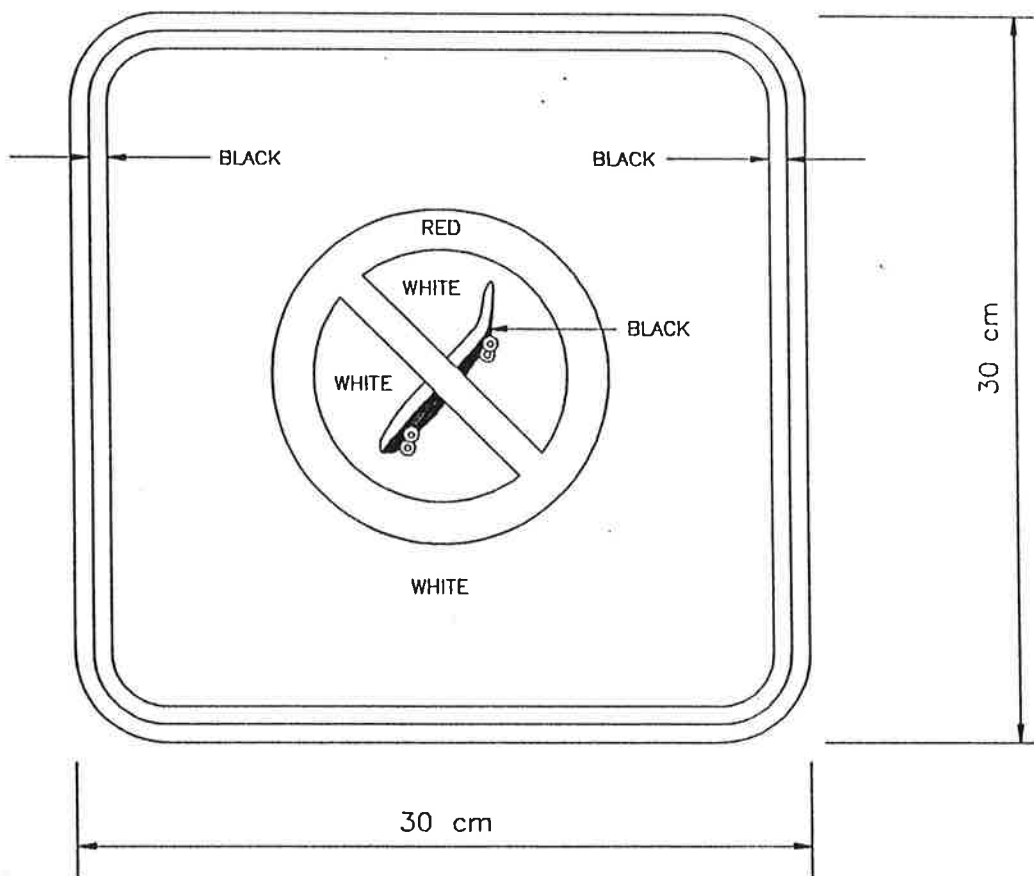

<b>CITY OF CORNWALL</b> ENGINEERING DEPARTMENT	DRAWN BY: A.J.A.
	DATE: 93-05-31
SCHEDULE XXVI NO SKATEBOARDING	SCALE: N.T.S.
	(Empty space)

**BY-LAW NO 88-1993 OF THE CITY OF CORNWALL**

A By-law to amend By-law No. 069, 1989  
as amended

\* \* \* \* \*

The Council of the Corporation of the City of Cornwall enacts as follows:

1. Schedule II (Parking Restrictions) of By-law No. 069, 1989 is hereby amended by repealing the following:

<u>COLUMN I</u>	<u>COLUMN II</u>	<u>COLUMN III</u>	<u>COLUMN IV</u>
<u>Highway</u>	<u>Side</u>	<u>Between</u>	<u>Prohibited Times/Days</u>
Queen Street	North	Hoople Avenue and Robertson Avenue	Anytime

2. Schedule II (Parking Restrictions) of By-law No. 069, 1989 is hereby amended by adding thereto the following:

<u>COLUMN I</u>	<u>COLUMN II</u>	<u>COLUMN III</u>	<u>COLUMN IV</u>
<u>Highway</u>	<u>Side</u>	<u>Between</u>	<u>Prohibited Times/Days</u>
Queen Street	North	Hoople Avenue and Second Street	Anytime
Queen Street	South	Hoople Avenue and Second Street	Anytime
Susan Avenue	East	Leonard Avenue and Queen Street	Anytime

Read a First and Second time in Open Council this 28th day of June, A.D. 1993.

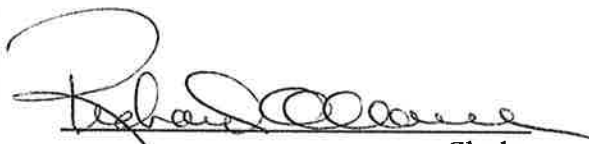
  
Clerk

  
Mayor

Read a Third time, PASSED, SIGNED and SEALED in Open Council this 28th day of June, A.D. 1993.

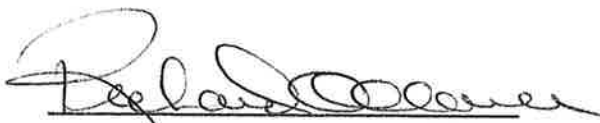
  
Clerk

  
Mayor

**BY-LAW NO. 105-1993 OF THE CITY OF CORNWALL**

A By-law to amend By-law No. 069, 1989  
as amended

\* \* \* \* \*

The Council of the Corporation of the City of Cornwall enacts as follows:

1. Schedule II (Parking Restrictions) of By-law No. 069, 1989 is hereby amended by adding thereto the following:

<u>COLUMN I</u>	<u>COLUMN II</u>	<u>COLUMN III</u>	<u>COLUMN IV</u>
<u>Highway</u>	<u>Side</u>	<u>Between</u>	<u>Prohibited Times/Days</u>
Baldwin Avenue	West	Second Street and Fourth Street	Anytime
Wellington Street East	South and West	Pitt Street and Northwoods Crescent (North)	Anytime
Twelfth Street East	North	Sydney Street and a point 15m east of the east limit of Adams Park	Anytime
Sunnyside Avenue	South	Pitt Street and Lascelle Avenue	Anytime

2. Schedule IV (Parking Restrictions - Time Limits) of By-law No. 069, 1989 is hereby amended by adding thereto the following:

<u>COLUMN I</u>	<u>COLUMN II</u>	<u>COLUMN III</u>	<u>COLUMN IV</u>	<u>COLUMN V</u>
<u>Highway</u>	<u>Side</u>	<u>Between</u>	<u>Restricted Times/Days</u>	<u>Maximum Period Permitted</u>
Augustus St.	West	First Street and Water St.	8:00 a.m. - 6:00 p.m. Monday to Friday	2 hours
Fifth St. East	North	Sydney Street to Pitt St.	8:00 a.m. - 6:00 p.m. Monday to Friday	2 hours

READ a First and Second Time in Open Council this 13th day of September, A.D. 1993.

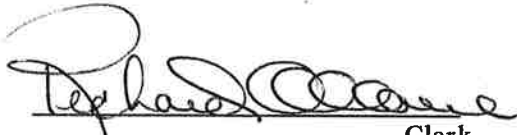
  
Clerk

  
Mayor

READ a Third time, PASSED, SIGNED and SEALED in Open Council this 13th day of September, A.D. 1993

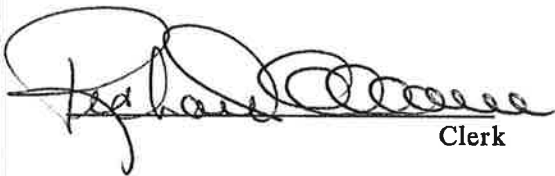
  
Clerk

  
Mayor

**BY-LAW NO. 106, 1993 OF THE CITY OF CORNWALL**

A By-law to amend By-law No. 069, 1989  
as amended

\* \* \* \* \*

The Council of the Corporation of the City of Cornwall enacts as follows:

1. Schedule XXVII (Skateboard Prohibition - Highways) of By-law No. 069, 1989 is hereby amended by adding thereto the following:

<b><u>COLUMN I</u></b>	<b><u>COLUMN II</u></b>	<b><u>COLUMN III</u></b>
<b><u>Highway</u></b>	<b><u>Between</u></b>	<b><u>Times/Days</u></b>
Boundary Road	Montreal Road and South Branch Road	Anytime
Brookdale Avenue	A point 670m north of Tollgate Road and Cornwall Centre Road	Anytime
Cornwall Centre Rd.	Vincent Massey Drive and Brookdale Avenue	Anytime
Marleau Avenue	Courtauld's Rail Spur and Campbell Street	Anytime
McConnell Avenue	Tollgate Road and South Branch Road	Anytime
Montreal Road	Transport Canada Training Institute Driveway and East Limit of Montreal Rd.	Anytime
Pitt Street	Tollgate Road and Carriere Avenue	Anytime
Power Dam Drive	A point 250m north of Jane Street, and Cornwall Centre Road	Anytime
Second Street	Campbell Street and Boundary Road	Anytime
South Branch Road	Pitt Street and Boundary Road	Anytime
Tenth Street	Virginia Drive and Boundary Road	Anytime
Tollgate Road	Vincent Massey Drive and McConnell Avenue	Anytime
Vincent Massey Dr.	Tollgate Road and the West Limit of Vincent Massey Drive	Anytime

2. Schedule XXVIII (Skateboard Prohibitions - Parks and City Property) of By-law No. 069, 1989 is hereby amended by adding thereto the following:

<u>COLUMN I</u>	<u>COLUMN II</u>	<u>COLUMN III</u>
<u>Property</u>	<u>Description</u>	<u>Times/Days</u>
Adams Park	Municipal Park, Sydney Street and Twelfth Street	Anytime
Alexander Park	Municipal Park, Eighth Street and Adolphus Street	Anytime
Alguire Park	Municipal Park, Dundee Avenue and Dewhurst	Anytime
Ashwood Greens	Municipal Park, Morris Street and Antoine	Anytime
Bell Centennial	Municipal Park, Dundas Crescent	Anytime
Blossom Park	Municipal Park, Anthony Street	Anytime
Boals Drain Linear	Benny Avenue & Meadowvale Cres.	Anytime
Broadview Park	Municipal Park, Thirteenth Street and Henry	Anytime
Carther Park	Municipal Park, Balmoral Avenue and Gage	Anytime
Chevrier Park	Municipal Park, Edgar Street and Wellington	Anytime
Dover Heights Park	Municipal Park, Robertson Avenue and Dover Road	Anytime
Gallinger Park	Municipal Park, Elsie Avenue and Lottie	Anytime
Glenview Heights Park	Municipal Park, Leitch Drive and Fraser	Anytime
Grants Subdivision	Municipal Park, Grant Avenue	Anytime
Guindon Park	Municipal Park, West Entrance to City (Highway 2)	Anytime
Horovitz Park	Municipal Park, First Street and Amelia	Anytime

<u>COLUMN I</u>	<u>COLUMN II</u>	<u>COLUMN III</u>
<u>Property</u>	<u>Description</u>	<u>Times/Days</u>
Joe St. Denis Park	Municipal Park, Marlborough Street and Fourth	Anytime
King George Park	Municipal Park, Seventh Street and York Street	Anytime
Kinsmen Park	Municipal Park, Third Street and Carleton	Anytime
Laframboise Park	Municipal Park, Balmoral Avenue	Anytime
Lamoureux Park	Municipal Park, Water Street West	Anytime
Lafave Park	Municipal Park, Anthony Street and Leonia	Anytime
Mattice Park	Municipal Park, Edward Street and Lennox	Anytime
Meadowvale Park	Municipal Park, Cobble Hill Road and Meadowvale	Anytime
Memorial Park	Municipal Park, Third Street and Bedford	Anytime
Menard Park	Municipal Park, Billington Drive and Bellevue	Anytime
Norman Park	Municipal Park, Norman Street	Anytime
Optimist Park	Municipal Park, Sunnyside Avenue and St. Michel	Anytime
Prince Arthur	Prince Arthur	Anytime
Riverdale Park	Municipal Park, Riverdale Avenue and Peter	Anytime
St. Francis de Sales	Second Street West	Anytime
St. Joseph's Park	Municipal Park, Easton Avenue and Jarvis	Anytime
Ste. Therese Park	Municipal Park, Thirteenth Street and Churchill	Anytime
Sara	Municipal Park, Sara Street	Anytime

<u>COLUMN I</u>	<u>COLUMN II</u>	<u>COLUMN III</u>
<u>Property</u>	<u>Description</u>	<u>Times/Days</u>
Silver Cross Park	Municipal Park, Tollgate Road and Pitt Street	Anytime
Terry Fox Park	Municipal Park, Mercier Avenue and Ross Avenue	Anytime
-----		
Boundary Road Reservoir	East Side of Boundary Road North of Second Street	Anytime
City Hall Annex	St. Felix Street	Anytime
Cornwall Civic Complex	Water Street	Anytime
Elevated Water Storage Tank	Tollgate Road East, West of McConnell	Anytime
Fire Station #1	Fourth Street West	Anytime
Fire Station #2	Second Street East	Anytime
Municipal Landfill Site	Cornwall Centre Road	Anytime
Richelieu Day Care Centre	York Street	Anytime
Wastewater Treatment Plant	Montreal Road	Anytime
Water Purification Plant	Second Street West	Anytime

READ a First and Second Time in Open Council this 13th day of September, A.D. 1993.

  
Clerk

  
Mayor

READ a Third time, PASSED, SIGNED and SEALED in Open Council this day of \_\_\_\_\_, A.D. 19\_\_.

\_\_\_\_\_  
Clerk

\_\_\_\_\_  
Mayor

**BY-LAW NO. 117-1993 OF THE CITY OF CORNWALL**

A By-law to amend By-law No. 069-1989  
as amended

\* \* \* \* \*

The Council of the Corporation of the City of Cornwall enacts as follows:

1. Schedule II (Parking Restrictions) of By-law No. 069-1989 is hereby amended by adding thereto the following:

<u>COLUMN I</u>	<u>COLUMN II</u>	<u>COLUMN III</u>	<u>COLUMN IV</u>
<u>Highway</u>	<u>Side</u>	<u>Between</u>	<u>Prohibited Times/Days</u>
Loyalist St.	North	Campbell Street to Education Road	Anytime
Loyalist St.	South	Campbell Street to Education Road	Anytime

Read a First and Second time in Open Council this 13th day of September, A.D. 1993.

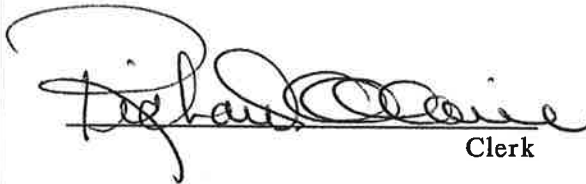
  
Clerk

  
Mayor

Read a Third time, PASSED, SIGNED and SEALED in Open Council this 13th day of September, A.D. 1993.

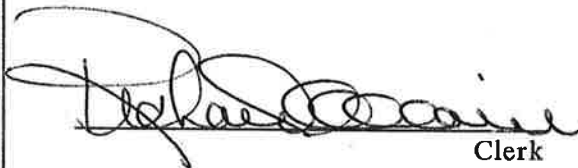
  
Clerk

  
Mayor

**BY-LAW NO. 121-1993 OF THE CITY OF CORNWALL**

*A By-law to amend By-law No. 069, 1989  
as amended*

\* \* \* \* \*

The Council of the Corporation of the City of Cornwall enacts as follows:

1. Schedule II (Parking Restrictions) of By-law No. 069, 1989 is hereby amended by adding thereto the following:

<u>COLUMN I</u>	<u>COLUMN II</u>	<u>COLUMN III</u>	<u>COLUMN IV</u>
<u>Highway</u>	<u>Side</u>	<u>Between</u>	<u>Prohibited Times/Days</u>
Birmingham Street	East	Balmoral Avenue and a point 45m north of Balmoral Avenue	8:00 a.m. - 6:00 p.m. Monday to Friday
Birmingham Street	West	Balmoral Avenue and a point 45m north of Balmoral Avenue	8:00 a.m. - 6:00 p.m. Monday to Friday

READ a First and Second Time in Open Council this 27th day of September, A.D. 1993.

  
Clerk

  
Mayor

READ a Third time, PASSED, SIGNED and SEALED in Open Council this 27th day of September, A.D. 1993

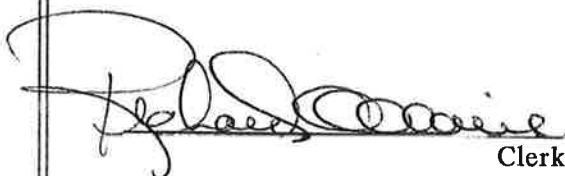
  
Clerk

  
Mayor

C

O

C

**BY-LAW NO. 03-1994 OF THE CITY OF CORNWALL**

A By-law to amend By-law No. 069, 1989  
as amended

\* \* \* \* \*

The Council of the Corporation of the City of Cornwall enacts as follows:

1. Schedule IV (Parking Restrictions - Time Limits) of By-law No. 069, 1989 is hereby amended by repealing the following:

<u>COLUMN I</u>	<u>COLUMN II</u>	<u>COLUMN III</u>	<u>COLUMN IV</u>	<u>COLUMN V</u>
<u>Highway</u>	<u>Side</u>	<u>Between</u>	<u>Restricted Times or Days</u>	<u>Maximum Period Permitted</u>
Park Street	North	Belmont Street and the east limit of Park Street	8:00 a.m. - 6:00 p.m. Mon. - Fri.	1 hour
Park Street	South	Belmont Street and the east limit of Park Street	8:00 a.m. - 6:00 p.m. Mon. - Fri.	1 hour

2. Schedule II (Parking Restrictions) of By-law No. 069, 1989 is hereby amended by adding thereto the following:

<u>COLUMN I</u>	<u>COLUMN II</u>	<u>COLUMN III</u>	<u>COLUMN IV</u>
<u>Highway</u>	<u>Side</u>	<u>Between</u>	<u>Prohibited Times/Days</u>
Park Street	North	Belmont Street and the east limit of Park Street	8:00 a.m. - 8:00 p.m. Mon. - Fri.
Park Street	South	Belmont Street and the east limit of Park Street	8:00 a.m. - 8:00 p.m. Mon. - Fri.

Read a First and Second time in Open Council this 10th day of January, A.D. 1994.

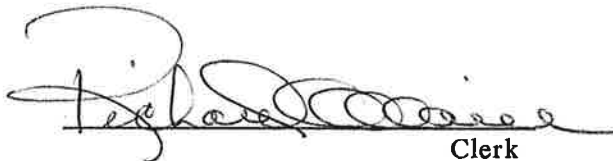
  
Clerk

  
Mayor

Read a Third time, PASSED, SIGNED and SEALED in Open Council this 10th day of January, A.D. 1994.

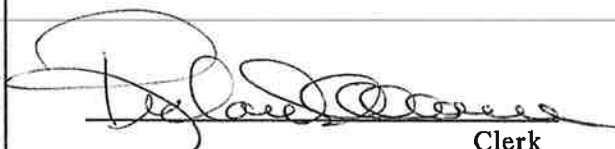
  
Clerk

  
Mayor

# BY-LAW NO. 090-1994 OF THE CITY OF CORNWALL

A by-law to amend By-law No. 069-1989  
as amended

\* \* \* \* \*

The Council of the Corporation of the City of Cornwall enacts as follows:

1. Schedule II (Parking Restrictions) of By-law No. 069-1989 is hereby amended by adding thereto the following.

<u>COLUMN I</u>	<u>COLUMN II</u>	<u>COLUMN III</u>	<u>COLUMN IV</u>
<u>Highway</u>	<u>Side</u>	<u>Between</u>	<u>Prohibited Times/Days</u>
First Street	South	A point 25 metres east of Mulberry Avenue and a point 55 metres east of Mulberry Avenue.	Anytime
Churchill Street	East	Fifteenth Street (west) and a point 20 metres south of Fifteenth Street (east)	Anytime
Churchill Street	West	A point 25 metres south of Fifteenth Street (west) and a point 40 metres further south.	8:00 a.m. - 6:00 p.m. Mon. - Fri.
Walton Street	South	McConnell Avenue and Prince Arthur Street	Anytime

Read a First and Second time in Open Council this 13th day of June, A.D. 1994.

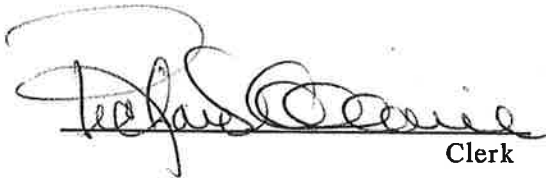
  
Clerk

  
Mayor

Read a third time, PASSED, SIGNED and SEALED in Open Council this 13th day of June, A.D. 1994.

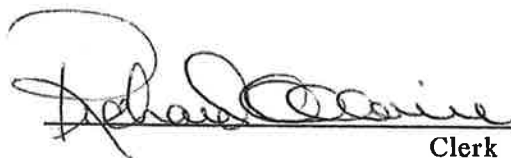
  
Clerk

  
Mayor

# BY-LAW NO. 112-1994 OF THE CITY OF CORNWALL

A by-law to amend By-law No. 069-1989  
as amended

\* \* \* \* \*

The Council of the Corporation of the City of Cornwall enacts as follows:

1. Schedule II (Parking Restrictions) of By-law No. 069-1989 is hereby amended by adding thereto the following.

<u>COLUMN I</u>	<u>COLUMN II</u>	<u>COLUMN III</u>	<u>COLUMN IV</u>
<u>Highway</u>	<u>Side</u>	<u>Between</u>	<u>Prohibited Times/Days</u>
Lochiel Street	North	Champlain Drive, and a point 200 meters east of Champlain Drive	8:00 a.m. - 6:00 p.m. Mon.-Fri.

Read a First and Second time in Open Council this 18th day of July, A.D. 1994.

  
Clerk

  
Mayor

Read a third time, PASSED, SIGNED and SEALED in Open Council this 18th day of July, A.D. 1994.

  
Clerk

  
Mayor

**BY-LAW NO. 113-1994 OF THE CITY OF CORNWALL**

A by-law to amend By-law No. 069-1989  
as amended

\* \* \* \* \*

The Council of the Corporation of the City of Cornwall enacts as follows:

1. Schedule XIV (Through Highways) of By-law No. 069-1989 is hereby amended by repealing the following:

<u>COLUMN I</u>	<u>COLUMN II</u>	<u>COLUMN III</u>
<u>Highway</u>	<u>From</u>	<u>To</u>
First Street East	East side of McConnell Avenue	West side of St. Felix Street

2. Schedule XIV (Through Highways) of By-law No. 069-1989 is hereby amended by adding thereto the following:

<u>COLUMN I</u>	<u>COLUMN II</u>	<u>COLUMN III</u>
<u>Highway</u>	<u>From</u>	<u>To</u>
First Street East	East side of McConnell Avenue	West side of Alice Street
First Street East	East side of Alice Street	West side of St. Felix Street

3. Schedule XV (Stop Signs) of By-law No. 069-1989 is hereby amended by adding thereto the following:

<u>COLUMN I</u>	<u>COLUMN II</u>
<u>INTERSECTION</u>	<u>FACING TRAFFIC</u>
Alice Street and First Street East	Northbound and southbound on Alice Street Eastbound and westbound on First Street East

Read a First and Second time in Open Council this 18th day of July, A.D. 1994.

  
Clerk

  
Mayor

Read a third time, PASSED, SIGNED and SEALED in Open Council this 18th day of July, A.D. 1994.

  
Clerk

  
Mayor

**BY-LAW NO. 143-1994 OF THE CITY OF CORNWALL**

*A by-law to amend By-law No. 069-1989  
as amended.*

\* \* \* \* \*

The Council of the Corporation of the City of Cornwall enacts as follows:

1. Schedule XV (Stop Signs) of By-law No. 069, 1989 is hereby amended by repealing the following:

**COLUMN I**

**COLUMN II**

**Intersection**

**Facing Traffic**

Cumberland Street and  
Emma Avenue

Eastbound and westbound  
on Emma Avenue

2. Schedule XV (Stop Signs) of By-law No. 069-1989 is hereby amended by adding thereto the following:

**COLUMN I**

**COLUMN II**

**Intersection**

**Facing Traffic**

Cumberland Street and  
Emma Avenue

Eastbound and westbound on  
Emma Avenue  
Northbound and southbound  
on Cumberland Street

Read a First and Second time in Open Council this 26th day of September,  
A.D. 1994.

  
Clerk

  
Mayor

Read a third time, **PASSED, SIGNED and SEALED** in Open Council this 26th  
day of September, A.D. 1994.

  
Clerk

  
Mayor

**BY-LAW 148-1994, OF THE CITY OF CORNWALL**

*A by-law to amend by-law 069-1989 as amended.*

\* \* \* \* \*

The Council of the Corporation of the City of Cornwall enacts as follows:

1. Schedule II (Parking Restrictions) of by-law 069-1989 is hereby amended by adding thereto the following:

<u>Column I</u>	<u>Column II</u>	<u>Column III</u>	<u>Column IV</u>
<u>Highway</u>	<u>Side</u>	<u>Between</u>	<u>Prohibited Times/Days</u>
Guy Street	West	Lasalle Road & St.Felix Street	Anytime

2. Schedule I (Stopping Restrictions) of by-law 069-1989 is hereby amended by adding thereto the following:

<u>Column I</u>	<u>Column II</u>	<u>Column III</u>	<u>Column IV</u>
<u>Highway</u>	<u>Side</u>	<u>Between</u>	<u>Prohibited Times/Days</u>
Brookdale Avenue	East	Fourteenth Street West & Sara Street	Anytime

READ a First and Second Time in Open Council this 24th day of October, 1994.

  
CLERK

  
MAYOR

READ a Third and Final Time, Signed and Sealed in Open Council this 24th day of October, 1994.

  
CLERK

  
MAYOR

# BY-LAW NO. 156-1994 OF THE CITY OF CORNWALL

A by-law to amend By-law No. 069-1989  
as amended

\* \* \* \* \*

The Council of the Corporation of the City of Cornwall enacts as follows:

1. Schedule XV (Stop Signs) of By-law No. 069-1989 is hereby amended by repealing the following:

COLUMN I

COLUMN II

Intersection

Facing Traffic

Edward Street and  
William Street

Southbound on Edward Street

2. Schedule XV (Stop Signs) of By-law No. 069-1989 is hereby amended by adding thereto the following:

COLUMN I

COLUMN II

Intersection

Facing Traffic

Edward Street and  
William Street

Southbound on Edward Street and  
eastbound on William Street

Ivan Crescent and  
Walton Street

Southbound on Ivan  
Crescent

Marguerite d'Youville  
Street and Walton Street

Northbound on Marguerite  
d'Youville Street

3. Schedule II (Parking Restrictions) of By-law No. 069-1989 is hereby amended by repealing the following:

COLUMN I

COLUMN II

COLUMN III

COLUMN IV

Highway

Side

Between

Prohibited  
Times/Days

William Street

South

Marlborough Street and  
Edward Street

Anytime

4. Schedule II (Parking Restrictions) of By-law No. 069-1989 is hereby amended by adding the following:

<u>COLUMN I</u>	<u>COLUMN II</u>	<u>COLUMN III</u>	<u>COLUMN IV</u>
<u>Highway</u>	<u>Side</u>	<u>Between</u>	<u>Prohibited Times/Days</u>
William Street	North	Edward Street and McConnell Avenue	Anytime
William Street	South	Marlborough Street and McConnell Avenue	Anytime

Read a First and Second time in Open Council this 21st day of November, A.D. 1994.

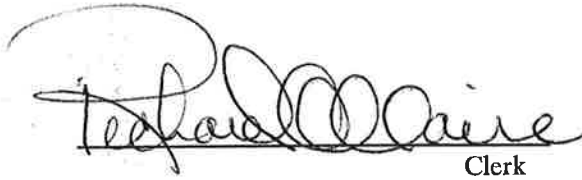
  
Clerk

  
Mayor

Read a third time, PASSED, SIGNED and SEALED in Open Council this 21st day of November, A.D. 1994.

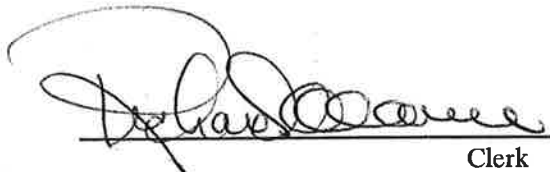
  
Clerk

  
Mayor

# BY-LAW NO. 168-1994 OF THE CITY OF CORNWALL

*A by-law to amend By-law No. 069-1989  
as amended*

\* \* \* \* \*

The Council of the Corporation of the City of Cornwall enacts as follows:

1. Schedule XIV (Through Highways) of By-law No. 069-1989 is hereby amended by repealing the following:

<u>COLUMN I</u>	<u>COLUMN II</u>	<u>COLUMN III</u>
<u>Highway</u>	<u>From</u>	<u>To</u>
Anthony Street	North side of Easton Avenue	South side of Holy Cross Boulevard

2. Schedule XIV (Through Highways) of By-law No. 069-1989 is hereby amended by adding thereto the following:

<u>COLUMN I</u>	<u>COLUMN II</u>	<u>COLUMN III</u>
<u>Highway</u>	<u>From</u>	<u>To</u>
Anthony Street	North side of Walton Street	South side of Holy Cross Boulevard

3. Schedule XV (Stop Signs) of By-law No. 069-1989 is hereby amended by adding thereto the following:

<u>COLUMN I</u>	<u>COLUMN II</u>
<u>Intersection</u>	<u>Facing Traffic</u>
Anthony Street and Walton Street	Northbound and southbound on Anthony Street  Eastbound and westbound on Walton Street

Read a Second time in Open Council this 12th day of December , A.D. 1994.

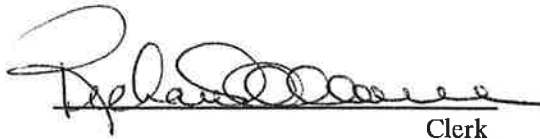
  
Clerk

  
Mayor

Read a third time, PASSED, SIGNED and SEALED in Open Council this 12th day of December, A.D. 1994.

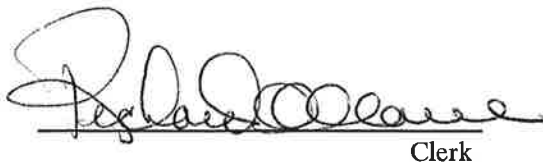
  
Clerk

  
Mayor



# BY-LAW NO. 52-1995 OF THE CITY OF CORNWALL

*A by-law to amend By-law No. 069-1989  
as amended*

\* \* \* \* \*

The Council of the Corporation of the City of Cornwall enacts as follows:

1. Schedule II (Parking Restrictions) of By-law No. 069-1989 is hereby amended by repealing the following:

<u>COLUMN I</u>	<u>COLUMN II</u>	<u>COLUMN III</u>	<u>COLUMN IV</u>
<u>Highway</u>	<u>Side</u>	<u>Between</u>	<u>Prohibited Times/Days</u>
William Street	North	Edward Street and McConnell Avenue	Anytime
William Street	South	Marlborough Street and McConnell Avenue	Anytime

2. Schedule II (Parking Restrictions) of By-law No. 069-1989 is hereby amended by adding the following:

<u>COLUMN I</u>	<u>COLUMN II</u>	<u>COLUMN III</u>	<u>COLUMN IV</u>
<u>Highway</u>	<u>Side</u>	<u>Between</u>	<u>Prohibited Times/Days</u>
Cotton Mill Street	North	Edward Street and McConnell Avenue	Anytime
Cotton Mill Street	South	Edward Street and McConnell Avenue	Anytime
William Street	South	Marlborough Street and Edward Street	Anytime

Read a First and Second time in Open Council this 24th day of April, A.D. 1995.

  
Clerk

  
Mayor

Read a third time, PASSED, SIGNED and SEALED in Open Council this 24th day of April, A.D. 1995.

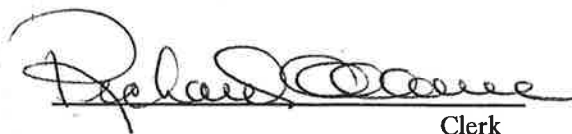
  
Clerk

  
Mayor

**BY-LAW NO. 069-1995 OF THE CITY OF CORNWALL**

*A by-law to amend By-law No. 069-1989 as amended.*

\*\*\*\*\*

The Council of the Corporation of the City of Cornwall enacts as follows:

1. Section 13 of by-law No. 069-1989 is hereby repealed and replaced as follows:

Winter Parking Restrictions

13. No person shall park a vehicle or permit a vehicle to remain parked on any highway between the hours of 1:00 a.m. of one day and 7:00 a.m. of the same day between November 15 of one year and March 31 of the following year.
2. The provisions of this by-law effecting traffic and highways designated as Connecting Links pursuant to the Public Transportation and Highway Improvement Act shall not become effective until approved by the Ontario Ministry of Transportation.

Read a FIRST and SECOND time in Open Council this 8th day of May, A.D. 1995.

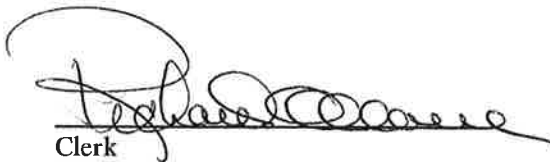
  
Clerk

  
Mayor

Read a THIRD time, PASSED, SIGNED and SEALED in Open Council this 8th day of May, A.D. 1995.

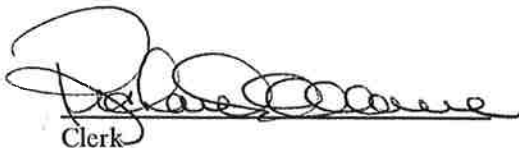
  
Clerk

  
Mayor

# BY-LAW NO. 111-1995 OF THE CITY OF CORNWALL

A by-law to amend By-law No. 069-1989  
as amended

\* \* \* \* \*

The Council of the Corporation of the City of Cornwall enacts as follows:

1. That Schedule IV (Parking Restrictions - Time Limits) be hereby amended by adding thereto the following:

<u>COLUMN I</u>	<u>COLUMN II</u>	<u>COLUMN III</u>	<u>COLUMN IV</u>	<u>COLUMN V</u>
			Restricted <u>Times/Days</u>	Maximum Period <u>Permitted</u> _____
Fourteenth Street	North	Pitt Street and Aubin Avenue	8:00 a.m. - 6:00 p.m. Mon. - Fri.	1 hour

Read a First and Second time in Open Council this 10th day of July, A.D. 1995.

  
Acting Mayor

  
Clerk

Read a third time, PASSED, SIGNED and SEALED in Open Council this 10th day of July, A.D. 1995.

  
Acting Mayor

  
Clerk

# BY-LAW NO. 116-1995 OF THE CITY OF CORNWALL

A by-law to amend By-law No. 069-1989  
as amended

\* \* \* \* \*

The Council of the Corporation of the City of Cornwall enacts as follows:

1. Schedule II (Parking Restrictions) of By-law No. 069-1989 is hereby amended by adding thereto the following:

<u>COLUMN I</u>	<u>COLUMN II</u>	<u>COLUMN III</u>	<u>COLUMN IV</u>
<u>Highway</u>	<u>Side</u>	<u>Between</u>	<u>Prohibited Times/Days</u>
Amelia Street	West	A point 17 metres north of Second Street East and a point 43 metres further north	8:00 a.m. - 6:00 p.m. Mon. - Fri. Sept.- June

2. Schedule VI (School Bus Loading Zones) of By-law No. 069-1989 is hereby amended by adding thereto the following:

<u>COLUMN I</u>	<u>COLUMN II</u>	<u>COLUMN III</u>	<u>COLUMN IV</u>	<u>COLUMN V</u>
<u>Highway</u>	<u>Side</u>	<u>Between</u>	<u>School or Institution</u>	<u>Prohibited Times/Days</u>
Amelia Street	West	Third Street and a point 90 metres south	Central Public School	8:00 a.m. - 6:00 p.m. Mon. - Fri. Sept.- June
Second Street East	North	A point 26 metres west of Amelia Street to a point 15 metres	Central Public School	8:00 a.m. - 6:00 p.m. Mon. - Fri.

Read a First and Second time in Open Council this 14th day of August, 1995.

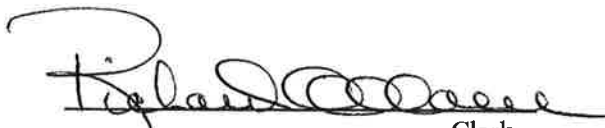
  
Clerk

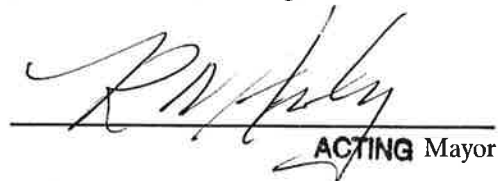
  
ACTING Mayor

Read a third time, PASSED, SIGNED and SEALED in Open Council this 14th day of August, 1995.

  
Clerk

  
ACTING Mayor

# BY-LAW NO. 117-1995 OF THE CITY OF CORNWALL

A by-law to amend By-law No. 069-1989  
as amended

\* \* \* \* \*

The Council of the Corporation of the City of Cornwall enacts as follows:

1. Schedule XV (Stop Signs) of By-law No. 069-1989 is hereby amended by adding the following:

COLUMN I

COLUMN II

Intersection

Facing Traffic

Seymour Avenue and  
Smith Lane

Westbound on Smith Lane

Dover Road and  
Shirley Avenue

Eastbound and westbound on  
Dover Road

2. Schedule VIII (Parking Meter Zones - On-Street) of By-law No. 069-1989 is hereby amended by adding the following:

COLUMN I

COLUMN II

COLUMN III

COLUMN IV

Highway

Side

From

To

McConnell Ave.

West

Montreal Road

A point 100  
metres north  
of Montreal  
Road

Read a First and Second time in Open Council this 14th day of August, A.D. 1995.

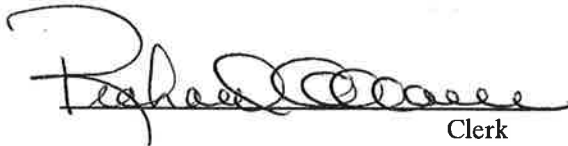
  
Clerk

  
ACTING Mayor

Read a third time, PASSED, SIGNED and SEALED in Open Council this 14th day of August, A.D. 1995.

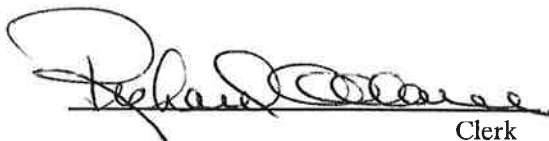
  
Clerk

  
ACTING Mayor

# BYLAW NO. 141, 1995 OF THE CITY OF CORNWALL

A bylaw to amend Bylaw No. 069, 1989  
as amended

\* \* \* \* \*

The Council of the Corporation of the City of Cornwall enacts as follows:

- Schedule XII (Designated Traffic Lanes) of Bylaw No. 069-1989 is hereby amended by adding thereto the following:

<u>COLUMN I</u>	<u>COLUMN II</u>	<u>COLUMN III</u>	<u>COLUMN IV</u>	<u>COLUMN V</u>
<u>Highway</u>	<u>Between</u>	<u>Lane</u>	<u>Directions</u>	<u>Times of Days</u>
Thirteenth Street East	A point 50m east of Pitt Street to a point 50m west of Sydney Street	First Lane from north curb	West and west to north	Anytime
Thirteenth Street East	A point 50m east of Pitt Street to a point 50m west of Sydney Street	Second Lane from north curb	West	Anytime
Thirteenth Street East	A point 50m east of Pitt Street to a point 50m west of Sydney Street	Third Lane from north curb	West to south and east to north	Anytime
Thirteenth Street East	A point 50m east of Pitt Street to a point 50m west of Sydney Street	Fourth Lane from north curb	East and east to south	Anytime

- Schedule II (Parking Restrictions) of Bylaw No. 069-1989 is hereby amended by adding thereto the following:

<u>COLUMN I</u>	<u>COLUMN II</u>	<u>COLUMN III</u>	<u>COLUMN IV</u>
<u>Highway</u>	<u>Side</u>	<u>Between</u>	<u>Prohibited Times or Days</u>
Prince Arthur Street	West	A point 45m south of Montreal Road and Prince Albert Street	8:00 a.m. - 6:00 p.m. Mon. - Fri.

3. Schedule XVIII (Heavy Trucks Prohibited) of Bylaw No. 069-1989 is hereby amended by adding thereto the following:

<u>COLUMN I</u>	<u>COLUMN II</u>	<u>COLUMN III</u>
<u>Highway</u> —	<u>Between</u> _____	<u>Times or Days</u>
William Street	Albert Street and Edward Street	Anytime
Paul Street	Eleventh Street and Twelfth Street	Anytime

4. Schedule V(a) (Loading Zones) of By-law 069, 1989 is hereby amended by repealing the following:

<u>COLUMN I</u>	<u>COLUMN II</u>	<u>COLUMN III</u>	<u>COLUMN IV</u>
<u>Highway</u> —	<u>Side</u> _____	<u>Between</u> _____	<u>Prohibited Times or Days</u>
Fourth Street	South	A point 116 metres east of Augustus Street and a point 20 metres further east	Anytime

Read a First and Second time in Open Council this 11th day of September, A.D. 1995.

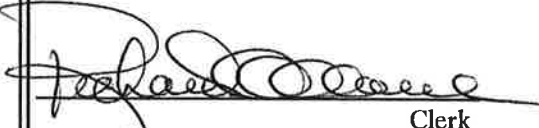
  
Clerk

  
Mayor

Read a third time, PASSED, SIGNED and SEALED in Open Council this 11th day of September, A.D. 1995.

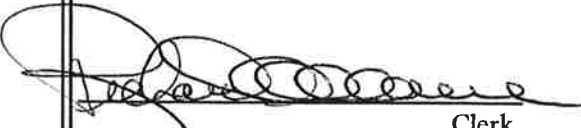
  
Clerk

  
Mayor

# BYLAW NO. 160, 1995 OF THE CITY OF CORNWALL

A bylaw to amend Bylaw No. 069, 1989  
as amended

\* \* \* \* \*

The Council of the Corporation of the City of Cornwall enacts as follows:

1. Schedule XVI (Yield Signs) of By-law No. 069-1989 is hereby amended by adding the following:

COLUMN I

COLUMN II

Intersection

Facing Traffic

Cotton Mill Street  
and Edward Street

Northbound on Edward Street  
turning east

Read a First and Second time in Open Council this 14th day of November, A.D. 1995.

---



Clerk



Mayor

Read a third time, PASSED, SIGNED and SEALED in Open Council this 14th day of November, A.D. 1995.

---

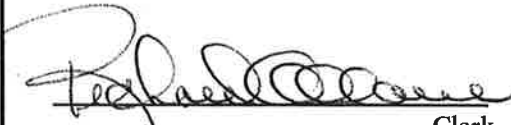

Clerk



Mayor

# BYLAW NO. 163, 1995 OF THE CITY OF CORNWALL

A bylaw to amend Bylaw No. 069, 1989  
as amended

\* \* \* \* \*

The Council of the Corporation of the City of Cornwall enacts as follows:

1) Section 1, subsection (29) of By-law No. 069-1989 is hereby repealed and replaced as follows:

(29) "parking meter zone" means that side and block of a highway where parking is controlled and regulated by parking meters; and shall also include municipal parking lots;

2) Section 20 of Bylaw No. 069-1989 is hereby repealed and replaced as follows:

20. (1) The streets or parts of streets as described in columns 1 through 4 of Schedule VIII to this by-law are hereby established as parking meter zones.

(2) Off-street parking zones, as described in columns 1, 2 and 3 of Schedule IX (a) to this by-law are hereby established as parking meter zones.

(3) Off-street parking zones, as described in columns 1, 2 and 3 of Schedule IX (b) to this by-law are hereby established as attendant parking zones.

(4) Municipal parking lots leased to and operated by the Downtown Merchants Board of Management are hereby designated as attendant parking zones.

3) Section 21 of Bylaw No. 069-1989 is hereby repealed and replaced as follows:

## Method of Use - Payment

21. (1) Where parking meters have been installed under the authority of this by-law, no person shall park a vehicle, or permit a vehicle to remain parked in a parking meter space within a parking meter zone or municipal parking lot unless the owner or operator of said vehicle, upon entering the said parking space:

(a) immediately deposits the required money in the parking meter alongside of or next to the said parking space; and

(b) activates the parking meter by turning the handle to indicate the unexpired time paid for in accordance with the hourly rate.

(1a) The hourly rate referred to in subsection (1) (b) shall be the rate indicated on the meter rate plate affixed to the meter nearest the parking space; and/or on the information plate affixed to the face of the "pay-and-display" machine; and/or as indicated on parking lot signage.

(1b) Compliance with subsections (1) and (4) of this section shall apply on:

Mondays, Tuesdays, and Wednesdays,  
between the hours of 9:00 a.m. and 6:00 p.m.

Thursdays and Fridays  
between the hours of 9:00 a.m. and 9:00 p.m.

except holidays.

(2) The provisions of subsection (1) shall not affect the privilege of the owner or operator of a vehicle of using the unexpired time as indicated on a parking meter.

(3) Within an attendant parking zone, no person shall park a vehicle or permit a vehicle to remain parked unless the owner or operator of said vehicle obtains an authorized ticket upon which the time of entry into said attendant parking zone is clearly indicated.

(4) Where a "pay-and-display" machine has been installed under the authority of this by-law, no person shall park a vehicle, or permit a vehicle to remain parked in a parking meter space within a municipal parking lot unless the owner or operator of said vehicle, upon entering the said parking lot:

(a) immediately deposits the required money in the "pay-and-display" machine controlling the parking meter space as indicated by signs;

(b) displays the valid and unexpired ticket issued by the "pay-and-display" machine clearly in sight, face up, on the left side of the front dashboard of the vehicle parked in said parking meter space, and in such a manner as to clearly show the parking lot name, date, and expiry time.

4) Section 22 of Bylaw No. 069-1989 is hereby repealed and replaced as follows:

*Bylaw 163-1995*

Time Limits

22. (1) Where parking meters or a "pay-and-display" machine have been installed under the authority of this by-law, no person shall park a vehicle, or permit a vehicle to remain parked in a parking meter space within a parking meter zone or municipal parking lot for a period of time in excess of the indicated time limit.
- (1a) Legal parking time limit referred to in subsection (1) shall be that time limit indicated: on the meter rate plate affixed to the meter nearest the parking space; and/or on the information plate affixed to the face of the "pay-and-display" machine; and/or as indicated on parking lot signage.
- (1b) Payment of the rate indicated as per Section 21 shall entitle the operator of a vehicle to park for the amount of time indicated next to the rate on the meter rate plate; and/or as indicated on the information plate affixed to the face of the "pay-and-display" machine; and/or as indicated on parking lot signage, subject to the provisions of Section 21 and this section.
- (1c) Compliance with subsection (1) of this section shall apply on:
- Monday, Tuesdays, Wednesdays and Saturdays between the hours of 9:00 a.m. and 6:00 p.m.  
Thursdays and Fridays between the hours of 9:00 a.m. and 9:00 p.m.
- except holidays.
- (2) Within a municipal parking lot or attendant parking zone, no person shall park a vehicle, or permit a vehicle to remain parked for a period of time in excess of twelve (12) hours
- (3) No person shall park a vehicle, or permit a vehicle to remain parked within an off-street parking meter zone or attendant parking zone in such a way as to interfere with the plowing or removing of snow or any other maintenance work undertaken by or on behalf of the Corporation.
- (4) Where a "pay-and-display" machine has been installed under the authority of this by-law, no person shall park a vehicle, or permit a vehicle to remain parked in a parking meter space within a parking lot on which an expired ticket is displayed.

5) Section 23, subsection (2) of Bylaw No. 069-1989 is hereby repealed and replaced as follows:

- (2) No person shall park a vehicle or permit a vehicle to remain parked in such a manner that it is not wholly within the area designated as a parking space unless the vehicle is of such length as to render it impossible to park it in one (1) parking space, in which case the adjoining parking space or spaces may, in addition, be used if the required coin deposits are made in the parking meters provided for all parking spaces used by the vehicle, and in compliance with all other sections of this by-law.

6) Section 25 of Bylaw No. 069-1989 is hereby repealed and replaced as follows:

Monthly Parking Permits

25. (1) Section 21 (1) of this by-law shall not apply to a motor vehicle having an overall length not exceeding 6.0 meters (19.7 feet) provided that such vehicle is parked:

- (a) at a meter displaying a legal time limit in excess of three (3) hours; or
- (b) within a designated area of an attendant parking zone, as indicated by signs; or
- (c) within a designated area of a municipal parking lot controlled with a "pay-and-display" machine, as indicated by signs,

subject to the provisions of subsections (2) and (3).

(2) A Monthly Parking Permit, issued by the Corporation of the City of Cornwall, valid for the current month, must be displayed:

- (a) against the driver's side of the windshield; or
- (b) attached to the rear view mirror of the vehicle in the case of a permit so designed.

such that the entire permit is clearly visible from outside the vehicle.

(3) Such permits shall apply on Mondays, Tuesdays, Wednesdays, Thursdays, and Fridays between the hours of 8:00 a.m. and 6:00 p.m., and are valid until the end of the calendar month for which they are issued unless otherwise revoked by the Corporation.

*Bylaw 163-1995*

7) Section 26 of Bylaw No. 069-1989 is hereby repealed and replaced as follows:

Commercial Motor Vehicle Parking Permits

26. (1) Section 21 (1) and 21 (4) of this by-law shall not apply to a commercial motor vehicle having an overall length not exceeding 6.0 metres (19.6 feet) provided the owner of such vehicle has obtained a Commercial Motor Vehicle Parking Permit, such permit shall be issued upon payment of the appropriate fee for each such commercial motor vehicle. Such permit is to be valid to the end of the calendar year for which it is issued, and is: to be installed on the lower right side of the windshield of the commercial motor vehicle for which it is issued; or to be attached to the rear view mirror of the commercial motor vehicle, for which it is issued, such that the entire permit is clearly visible from outside the vehicle.
- (2) The operator of a commercial motor vehicle for which a Commercial Motor Vehicle Parking Permit has been issued under subsection (1) shall have the privilege of parking in any designated parking meter zone, without the use of a coin, for a period time long enough to carry out official business, but under no circumstances for a longer period of time than one hour.
- (3) If for any reason such as a broken windshield or the sale of the vehicle, the person to whom the original permit was issued under subsection (1) can produce the old permit or pieces of it, a new or replacement permit may be issued at a cost of Five (\$5.00) Dollars.

8) Section 60, subsection (2) of Bylaw No. 069-1989 is hereby repealed and replaced as follows:

60. (2) **"fire route"** means a route which is continuous along its entire length and shall extend from a public highway to a designated building and return to a public highway, and without limiting the generality of the foregoing includes any private roadway, road, driveway, lane, ramp or other means of vehicular access or egress to or exit from a designated building and shall include any part of a parking lot set aside by visible markings or markers for the purpose of motor vehicle movement. Such fire access route must be indicated in accordance with Section 61 of this by-law.

*Bylaw 163-1995*

9) Section 61, subsection (1) of Bylaw No. 069-1989 is hereby repealed and replaced as follows:

61. (1) The authorized fire route sign shall be as shown in Schedule XXIV of this by-law.

10) The provisions of this by-law effecting traffic and highways designated as Connecting Links pursuant to the Public Transportation and Highway Improvement Act shall not become effective until approved by the Ontario Ministry of Transportation.

11) Except as provided in Section 10, this by-law shall come into force on the first day of January, 1996.

Read a First and Second time in Open Council this 27th day of November, A.D. 1995.

  
Clerk

  
Mayor

Read a third time, PASSED, SIGNED and SEALED in Open Council this 27th day of November, A.D. 1995.

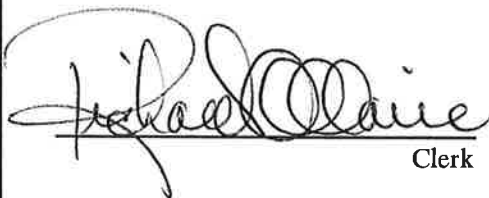
  
Clerk

  
Mayor

# BY-LAW NO.055-1996 OF THE CITY OF CORNWALL

*A by-law to amend By-law No.069-1989 as amended*

\* \* \* \* \*

The Council of the Corporation of the City of Cornwall enacts as follows:

1) Section 36 of By-law No. 069-1989 is hereby repealed and replaced as follows:

(36) When any highway or portion of highway set out in Schedule XX (a), (b), (c), or (d) appended hereto is marked in accordance with the regulations under the Highway Traffic Act, the maximum rate of speed thereon shall be the rate of speed prescribed in the Schedule.

2) By-law No.069-1989 is hereby amended by adding thereto the following:

### SCHEDULE XX (d) RATES OF SPEED ON HIGHWAYS

- 1 -

#### MAXIMUM RATE OF SPEED - 40 KILOMETERS PER HOUR (Km/h)

COLUMN I	COLUMN II
<u>HIGHWAY</u>	<u>BETWEEN</u>
Holy Cross Boulevard	Dean Drive/Paulette Street and Hamilton Crescent

3. Schedule XIV (Through Highways) of By-law No. 069-1989 is hereby amended by repealing the following:

<u>COLUMN I</u>	<u>COLUMN II</u>	<u>COLUMN III</u>
<u>Highway</u>	<u>Side</u>	<u>Between</u>
Dover Road	East side of Pescod Ave.	North side of Queen St.
Seventh St.	East side of Cumberland St.	West side of Amelia St.

4. Schedule XV (Stop Signs) of By-law No. 069-1989 is hereby amended by repealing the following:

<u>COLUMN I</u>	<u>COLUMN III</u>
<u>Intersection</u>	<u>Facing Traffic</u>
Cumberland St. and Ellen Ave.	Eastbound and westbound on Ellen Ave.

5. Schedule XV (Stop Signs) of By-law No. 069-1989 is hereby amended by adding the following:

COLUMN I

COLUMN III

Intersection

Facing Traffic

Augustus St. and Seventh St.	Southbound on Augustus St.
Augustus St. and Trinity Ave.	Eastbound on Trinity Ave.
Bedford St. and Seventh St.	Northbound on Bedford St.
Cumberland St. and Ellen Ave. (North intersection)	Northbound on Ellen Ave.
Cumberland St. and Ellen Ave. (South intersection)	Eastbound and Westbound on Ellen Ave.
Dover Rd. and Joyce St.	Southbound on Joyce St.
Dover Rd. and Susan Ave.	Northbound on Susan Ave.
Dover Rd. and Westmooreland Ave.	Northbound on Westmooreland Ave.
Dover Rd. and Princess St./ Robertson Ave.	Northbound on Robertson Ave. Eastbound on Princess St.
Seventh St. and York St.	Northbound and Southbound on York St. Eastbound and Westbound on Seventh St.

6. Schedule XVI (Yield Signs) of By-law No. 069-1989 is hereby amended by repealing the following:

COLUMN I

COLUMN III

Intersection

Facing Traffic

Laura Cres.(North) and Paulette St.	Westbound on Laura Cres. (North)
-------------------------------------	----------------------------------

7. Schedule XVI (Yield Signs) of By-law No. 069-1989 is hereby amended by adding the following:

COLUMN I

COLUMN III

Intersection

Facing Traffic

Dean Dr. and Jo-Anne Cres. (North)	Westbound on Jo-Anne Cres. (North)
------------------------------------	------------------------------------

Read a First and Second time in Open Council this 9th day of April, A.D. 1996.

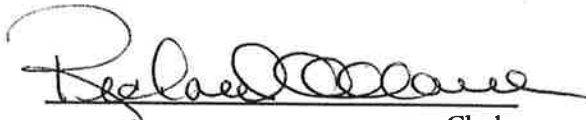
  
Clerk

  
Mayor

Read a third time, PASSED, SIGNED and SEALED in Open Council this 9th day of April, A.D. 1996.

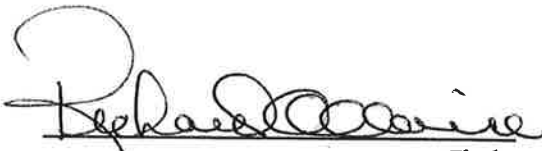
  
Clerk

  
Mayor

# BY-LAW NO. 069-1996 OF THE CITY OF CORNWALL

A by-law to amend By-law No. 069-1989  
as amended

\* \* \* \* \*

The Council of the Corporation of the City of Cornwall enacts as follows:

1. Schedule XIV (Through Highways) of By-law No. 069-1989 is hereby amended by repealing the following:

<u>COLUMN I</u>	<u>COLUMN II</u>	<u>COLUMN III</u>
<u>Highway</u>	<u>Side</u>	<u>Between</u>
Pitt Street	South side of Third Street	South side of Cornwall Centre Road

2. Schedule XIV (Through Highways) of By-law No. 069-1989 is hereby amended by adding thereto the following:

<u>COLUMN I</u>	<u>COLUMN II</u>	<u>COLUMN III</u>
<u>Highway</u>	<u>Side</u>	<u>Between</u>
Pitt Street	North side of Third Street	South side of Cornwall Centre Road

3. Schedule XV (Stop Signs) of By-law No. 069-1989 is hereby amended by adding thereto the following:

<u>COLUMN I</u>	<u>COLUMN III</u>
<u>Intersection</u>	<u>Facing Traffic</u>
Pitt Street and Third Street	Southbound on Pitt Street
	Eastbound and westbound on Third Street

Read a First and Second time in Open Council this 27th day of May, A.D. 1996.

  
Clerk

  
Mayor

Read a third time, PASSED, SIGNED and SEALED in Open Council this 27th day of May, A.D. 1996.

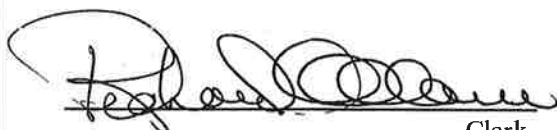
  
Clerk

  
Mayor

# BY-LAW NO. 070-1996 OF THE CITY OF CORNWALL

A by-law to amend By-law No. 069-1989  
as amended

\* \* \* \* \*

The Council of the Corporation of the City of Cornwall enacts as follows:

1. Schedule II (Parking Restrictions) of By-law No. 069-1989 is hereby amended by repealing the following:

<u>COLUMN I</u>	<u>COLUMN II</u>	<u>COLUMN III</u>	<u>COLUMN IV</u>
<u>Highway</u>	<u>Side</u>	<u>Between</u>	<u>Prohibited Times/Days</u>
Arthur Street	West	Montreal Road and William Street	Anytime
Marlborough Street	East	Montreal Road and Harbour Road	Anytime

2. Schedule II (Parking Restrictions) of By-law No. 069-1989 is hereby amended by adding the following:

<u>COLUMN I</u>	<u>COLUMN II</u>	<u>COLUMN III</u>	<u>COLUMN IV</u>
<u>Highway</u>	<u>Side</u>	<u>Between</u>	<u>Prohibited Times/Days</u>
Arthur Street	East	Montreal Road and Lennox Avenue	Anytime
Arthur Street	West	Lennox Avenue and William Street	Anytime
Marlborough Street	West	Montreal Road and Harbour Road (south limit of Marlborough Street)	Anytime

3. Schedule IV (Parking Restrictions - Time Limits) hereby amended by adding thereto the following:

<u>COLUMN I</u>	<u>COLUMN II</u>	<u>COLUMN III</u>	<u>COLUMN IV</u>	<u>COLUMN V</u>
			<u>Restricted Times/Days</u>	<u>Maximum Period Permitted</u>
Arthur Street	West	A point 15m south of Montreal Road to a point 15m further south	8:00 a.m. - 6:00 p.m. Mon. - Fri.	1 hour
Arthur Street	West	A point 30m south of Montreal Road to a point 10m north of Lennox Ave.	8:00 a.m. - 6:00 p.m. Mon. - Fri.	2 hours

Read a First and Second time in Open Council this 27th day of May, A.D. 1996.

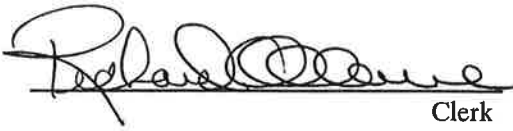
  
Clerk

  
Mayor

Read a third time, PASSED, SIGNED and SEALED in Open Council this 27th day of May, A.D. 1996.

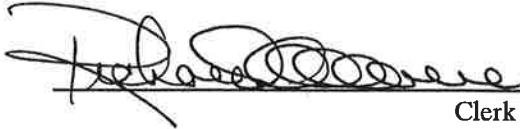
  
Clerk

  
Mayor

# BY-LAW NO. 117-1996 OF THE CITY OF CORNWALL

*A by-law to amend by-law No. 069-1989  
as amended.*

\* \* \* \* \*

The Council of the Corporation of the City of Cornwall enacts as follows:

1. Schedule IV (Parking Restrictions - Time Limits) of By-law No. 069-1989 is hereby amended by repealing therefrom the following:

<u>COLUMN I</u>	<u>COLUMN II</u>	<u>COLUMN III</u>	<u>COLUMN IV</u>	<u>COLUMN V</u>	
<u>Highway</u>	<u>Side</u>	<u>Between</u>	<u>Restricted Times or Days</u>	<u>Maximum Period Permitted</u>	
By-law 085/92	Ridgewood Drive	North	Marlborough Street and McConnell Avenue	8:00 a.m. 6:00 p.m. Mon. - Fri.	2 hours

2. Schedule II (Parking Restrictions) of By-law No. 069-1989 is hereby amended by adding thereto the following:

<u>COLUMN I</u>	<u>COLUMN II</u>	<u>COLUMN III</u>	<u>COLUMN IV</u>
<u>Highway</u>	<u>Side</u>	<u>Between</u>	<u>Prohibited Times or Days</u>
Ridgewood Drive	North	Marlborough Street and McConnell Avenue	Anytime

READ a First and Second Time in Open Council this 12th day of November, 1996.

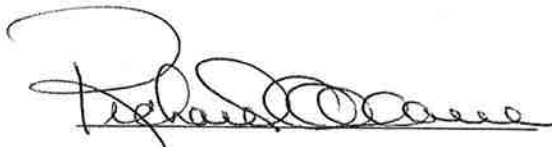
  
CLERK

  
MAYOR

READ a Third and Final Time, Signed and Sealed in Open Council this 12th day of November, 1996.

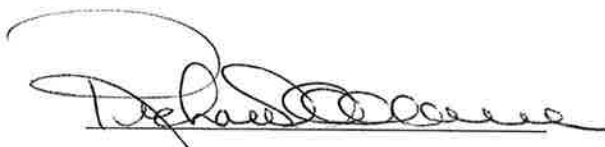
  
CLERK

  
MAYOR

BY-LAW 121-1996, OF THE CITY OF CORNWALL

A by-law to amend the Traffic By-law, 069-1989,  
as amended.

\*\*\*\*\*

The Council of the Corporation of the City of Cornwall enacts as follows:

- 1. Schedule VI (School Bus Loading Zones) of By-law No. 069-1989 is hereby amended by repealing thereto the following:

<u>COLUMN I</u>	<u>COLUMN II</u>	<u>COLUMN III</u>	<u>COLUMN IV</u>	<u>COLUMN V</u>
<u>Highway</u>	<u>Side</u>	<u>Between</u>	<u>School or Institution</u>	<u>Prohibited Times or Days</u>
Cumberland Street	West	A point 75 m. north of Fifteenth St. and to a point 50 m. further north.	Vincent Massey Public School	Anytime

- 2. Schedule VI (School Bus Loading Zones) of By-law No. 069-1989 is hereby amended by adding thereto the following:

<u>COLUMN I</u>	<u>COLUMN II</u>	<u>COLUMN III</u>	<u>COLUMN IV</u>	<u>COLUMN V</u>
<u>Highway</u>	<u>Side</u>	<u>Between</u>	<u>School or Institution</u>	<u>Prohibited Times or Days</u>
Cumberland Street	West	A point 43 m. north of Fifteenth St. and to a point 75 m. further north.	Vincent Massey Public School	Anytime

READ a First and Second Time in Open Council this 25th day of November, 1996.

  
CLERK

  
MAYOR

READ a Third and Final Time, Signed and Sealed in Open Council this 25th day of November, 1996.

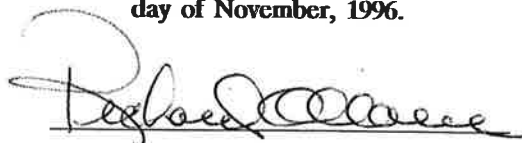
  
CLERK

  
MAYOR

BY-LAW 005-1997, OF THE CITY OF CORNWALL

A by-law to amend the Traffic  
By-law 069-1989, as amended.

\* \* \* \* \*

The Council of the Corporation of the City of Cornwall enacts  
as follows:

**THAT** Section 21 (1b) is hereby amended by deleting therefrom  
the following:

Compliance with subsections (1) and (4) of this Section shall apply, except  
holidays, on Monday, Tuesday, and Wednesdays between the hours of 9:00 a.m. and 6:00  
p.m. and Thursdays and Fridays between the hours of 9:00 a.m. and 9:00 p.m.

**THAT** Section 21 (1b) is hereby amended by adding thereto the following:

Compliance with subsections (1) and (4) of this Section shall  
apply, except holidays, on Mondays through Fridays between the hours of 9:00 a.m. and  
6:00 p.m.

**THAT** Section 22 (1c) is hereby amended by deleting therefrom  
the following:

Compliance with subsection (1) of this Section shall apply, except holidays, on  
Mondays, Tuesdays, Wednesdays and Saturdays between the hours of 9:00 a.m. and 6:00  
p.m.; and Thursdays and Fridays between the hours of 9:00 a.m. and 9:00 p.m..

**THAT** Section 22 (1c) is hereby amended by adding thereto the  
following:

Compliance with subsection (1) of this Section shall apply, except holidays, on  
Mondays through Saturdays, between the hours of 9:00 a.m. and 6:00 p.m.

READ a First and Second Time in Open Council this 13th day of January,  
1997.

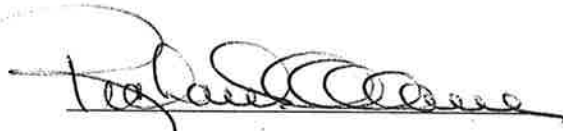

CLERK



MAYOR

READ a Third and Final Time, Signed and Sealed in Open Council this 13th  
day of January, 1997.

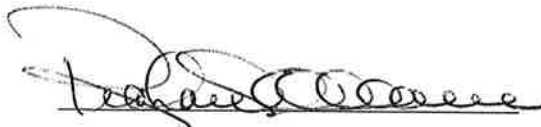

CLERK



MAYOR

**BY-LAW 011-1997, OF THE CITY OF CORNWALL**

A by-law to amend the Traffic  
By-law 069, 1989, as amended.

\*\*\*\*\*

The Council of the Corporation of the City of Cornwall enacts  
as follows:

**THAT** Section 22 (1c) be amended by deleting therefrom the following:

(1c) Compliance with Subsection (1) of this Section shall apply, except holidays,  
on Monday through Saturday, between the hours of 9:00 a.m. and 6:00 p.m.

**THAT** Section 22 (1c) be amended by adding thereto the  
following:

(1c) Compliance with Subsection (1) of this Section shall apply, except holidays,  
on Monday through Friday, between the hours of 9:00 a.m. and 6:00 p.m.

READ a First and Second Time in Open Council this 27th day of January,  
1997.



CLERK



MAYOR

READ a Third and Final Time, Signed and Sealed in Open Council this 27th  
day of January, 1997.

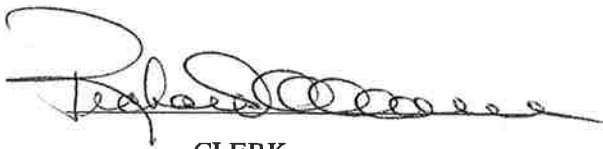

CLERK



MAYOR

**BY-LAW 031-1997, OF THE CITY OF CORNWALL**

A by-law to amend By-law No. 069,  
1989, as amended.

\*\*\*\*\*

The Council of the Corporation of the City of Cornwall enacts as follows:

1. That Schedule 2 (Parking Restrictions) be hereby amended by adding thereto the following:

<b>Highway</b>	<b>Side</b>	<b>Between</b>	<b>Prohibited Times or Days</b>
Sydney Street	East	Between Fifth and a point 62 metres north of Sixth Street.	Anytime

READ a First and Second Time in Open Council this 24th day of March, 1997.

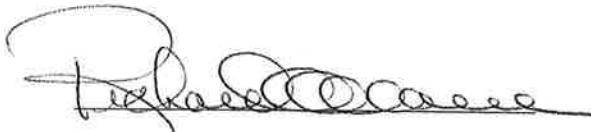
  
CLERK

  
MAYOR

READ a Third and Final Time, Signed and Sealed in Open Council this 24th day of March, 1997.

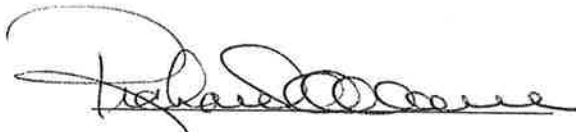
  
CLERK

  
MAYOR

**BY-LAW 038-1997, OF THE CITY OF CORNWALL**

A by-law to amend By-law No. 069,  
1989, as amended.



\*\*\*\*\*

The Corporation of the City of Cornwall enacts as follows:

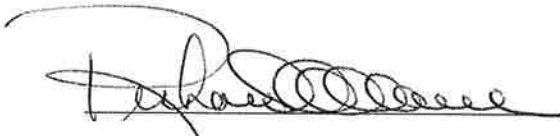

1. THAT Schedule 2 (Parking Restrictions) be hereby amended by adding thereto the following:

<b>HIGHWAY</b>	<b>SIDE</b>	<b>BETWEEN</b>	<b>PROHIBITED TIMES OR DAYS</b>
McKay Avenue	North	Baldwin Avenue and a point 43 metres east of Baldwin Avenue.	Anytime

READ a First and Second Time in Open Council this 14th day of April, 1997.

  
CLERK  
MAYOR  
ACTING MAYOR

READ a Third and Final Time, Signed and Sealed in Open Council this 14th day of April, 1997.

  
CLERK  
MAYOR  
ACTING MAYOR

**BY-LAW 073-1997, OF THE CITY OF CORNWALL**

A by-law to amend By-law No. 069,  
1989, as amended.

\* \* \* \* \*

The Corporation of the City of Cornwall enacts as follows:

1. The Traffic and Parking By-law No.069, 1989, is amended by deleting therefrom the following:

64. The Traffic Engineer for the Corporation of the City of Cornwall is hereby authorized to place or erect and to maintain such official or authorized signs and traffic control signs or devices and parking meters as are required to give effect to the provisions of this by-law or as required to warn or guide traffic for the safety and convenience of the public.

2. The Traffic and Parking By-law No.069, 1989, is amended by adding thereto the following:

64. The Traffic Engineer for the Corporation of the City of Cornwall is hereby authorized to place or erect and to maintain such official or authorized signs, traffic control signals, under Section 144 (31) of the Highway Traffic Act, or devices and parking meters as are required to give effect to the provisions of this by-law or as required to warn or guide traffic for the safety and convenience of the public.

READ a First and Second Time in Open Council this 23rd day of June, 1997.

  
Deputy CLERK

  
MAYOR

READ a Third and Final Time, Signed and Sealed in Open Council this 23rd day of June, 1997.

  
Deputy CLERK

  
MAYOR

**BY-LAW 078-1997, OF THE CITY OF CORNWALL**

A by-law to amend By-law 069,  
1989, as amended.

\*\*\*\*\*

The Council of the Corporation of the City of Cornwall enacts as follows:

1. That Schedule II of the Traffic & Parking By-law No. 069, 1989, be hereby amended by adding thereto the following:

<b>HIGHWAY</b>	<b>SIDE</b>	<b>BETWEEN</b>	<b>PROHIBITED TIMES OR DAYS</b>
Iroquois Drive	West	St. Felix St. and a point 100 metres north of St. Felix St.	Anytime

READ a First and Second Time in Open Council this 23rd day of June, 1997.

  
Deputy CLERK

  
MAYOR

READ a Third and Final Time, Signed and Sealed in Open Council this 23rd day of June, 1997.

  
Deputy CLERK

  
MAYOR

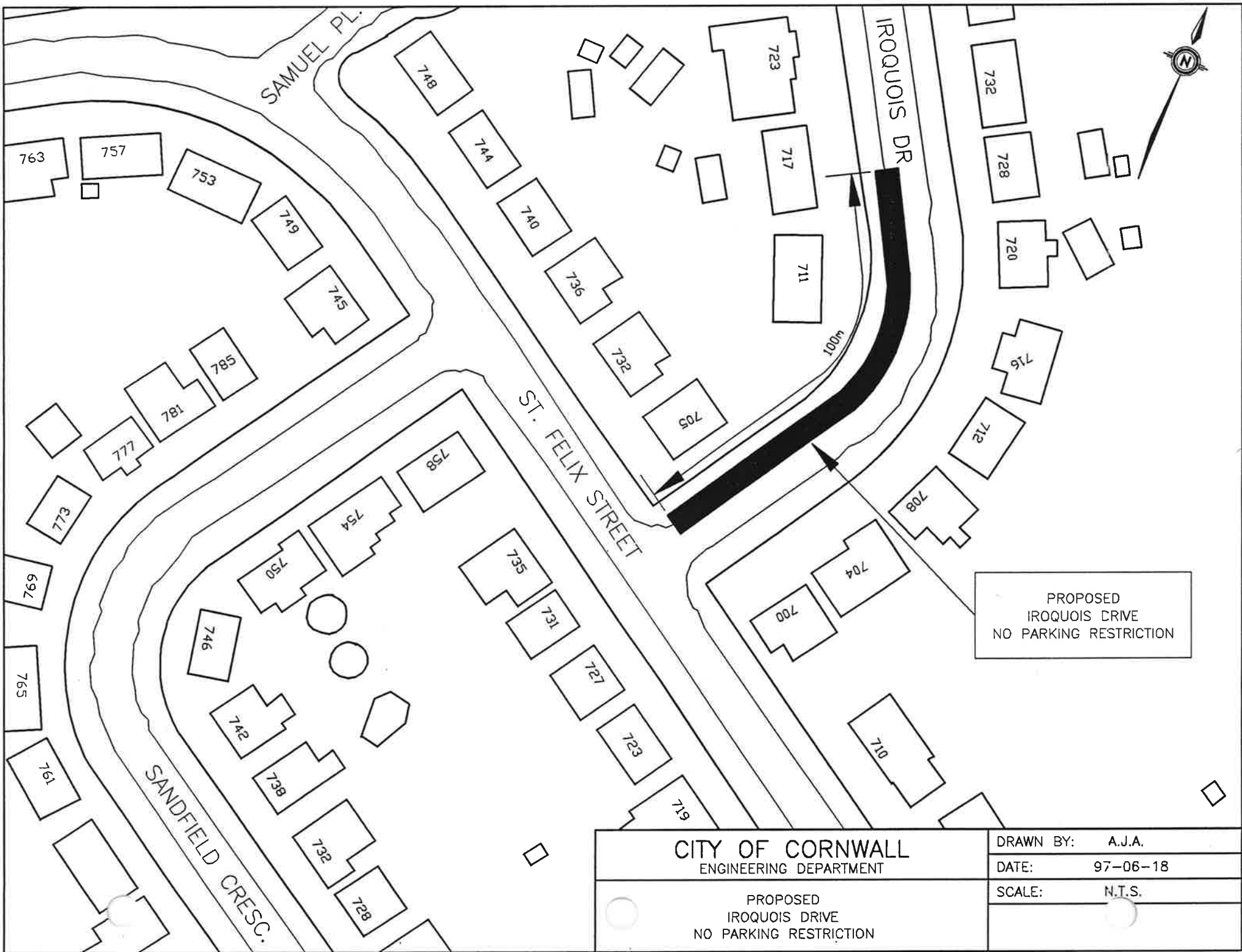

PROPOSED  
IROQUOIS DRIVE  
NO PARKING RESTRICTION

<b>CITY OF CORNWALL</b> ENGINEERING DEPARTMENT	DRAWN BY: A.J.A.
	DATE: 97-06-18
PROPOSED IROQUOIS DRIVE NO PARKING RESTRICTION	SCALE: N.T.S.

BY-LAW 079-1997, OF THE CITY OF CORNWALL

A by-law to amend By-law 069,  
1989, as amended.

\*\*\*\*\*

The Council of the Corporation of the City of Cornwall enacts as follows:

1. That Schedule V (a) of the Traffic & Parking By-law No. 069, 1989, be amended by deleting therefrom the following:

HIGHWAY	SIDE	BETWEEN	PROHIBITED TIMES OR DAYS
Third Street	North	A point 52 metres west of Pitt St. and a point 30 metres further west.	Anytime

READ a First and Second Time in Open Council this 23rd day of June, 1997.

  
Deputy CLERK

  
MAYOR

READ a Third and Final Time, Signed and Sealed in Open Council this 23rd day of June, 1997.

  
Deputy CLERK

  
MAYOR

**By-law No.087-1997 of the City of Cornwall**

*A by-law to amend by-law 069-1989, the Traffic By-law.*

**WHEREAS** The Corporation of the City of Cornwall is desirous of amending by-law 069-1989, known as the Traffic By-law, in order to prohibit skateboarding on library property and in the City parking lot immediately north of the property.

**NOW THEREFORE**, the Council of The Corporation of the City of Cornwall hereby enacts as follows:

1. That Schedule XXVIII of the Traffic and Parking By-law, 069-1989 is amended by deleting therefrom the following:

<u>Property</u>	<u>Description</u>	<u>Times/Day</u>
Third Street East Lot	Mid block on Third Street between Sydney Street and Pitt Street - South Side.	Anytime

2. That Schedule XXVIII of the Traffic and Parking By-law, 069-1989 is amended by adding thereto the following:

<u>Property</u>	<u>Description</u>	<u>Times/Day</u>
Third Street Lot	Center block of Pitt Street to Sydney Street, and Second Street to Third Street, including access roadways.	Anytime
Library	45 Second Street East	Anytime

**READ A FIRST AND SECOND TIME**, in Open Council this 14th day of July, 1997.

  
\_\_\_\_\_  
Mayor **ACTING**

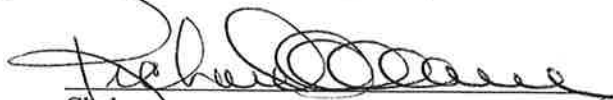
  
\_\_\_\_\_  
Clerk

**READ A THIRD TIME, PASSED, SIGNED AND SEALED** in Open Council this 14th day of July, 1997.

  
\_\_\_\_\_  
Mayor **ACTING**

  
\_\_\_\_\_  
Clerk

**BY-LAW 115-1997, OF THE CITY OF CORNWALL**

*A by-law to amend the Traffic and Parking By-law, 069-1989, as amended. (Speed limits on Cornwall Center Road, McConnell Avenue, and South Branch Road).*

\*\*\*\*\*

**WHEREAS** The Corporation of the City of Cornwall is desirous of amending by-law 069-1989, known as the Traffic and Parking By-law, in order to ensure that appropriate limits are posted which reflect the particular conditions on the given roadways.

**NOW THEREFORE** the Council of the Corporation of the City of Cornwall enacts as follows:

1. That Schedule XX(a) of the Traffic and Parking By-law, 069-1989 is hereby amended by deleting therefrom the following:

HIGHWAY	BETWEEN
Cornwall Centre Road McConnell Avenue South Branch Road	Brookdale Avenue and Vincent Massey Drive Tollgate Road and South Branch Road Pitt Street and Boundary Road

2. That Schedule XX(a) of the Traffic and Parking By-law, 069-1989 is hereby amended by adding thereto the following:

HIGHWAY	BETWEEN
Cornwall Centre Road South Branch Road	Power Dam Drive and Vincent Massey Drive Pitt Street and McConnell Avenue

3. That Schedule XX(b) of the Traffic and Parking By-law, 069-1989 is hereby amended by adding thereto the following:

HIGHWAY	BETWEEN
Cornwall Centre Road McConnell Avenue South Branch Road	Brookdale Avenue and Power Dam Drive Highway #401 and South Branch Road Boundary Road and McConnell Avenue

READ a First and Second Time in Open Council this 8<sup>th</sup> day of September, 1997.

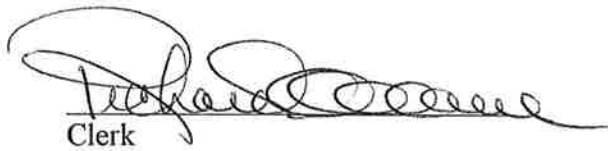
  
Clerk

  
Mayor

READ a Third and Final Time, Signed and Sealed in Open Council this 8<sup>th</sup> day of September, 1997.

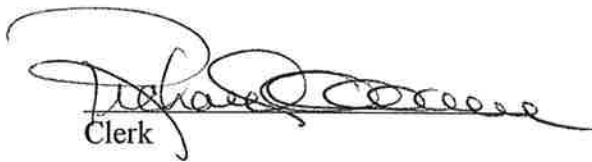
  
Clerk

  
Mayor

**BY-LAW 117-1997, OF THE CITY OF CORNWALL**

*A by-law to amend the Traffic and Parking  
By-law, 069-1989, as amended. (Heavy  
Vehicles).*

\*\*\*\*\*

**WHEREAS** The Corporation of the City of Cornwall is desirous of amending by-law 069-1989, known as the Traffic and Parking By-law, in order to revise the classification of "heavy vehicles".

**NOW THEREFORE** the Council of the Corporation of the City of Cornwall enacts as follows:

1. That Section 1 of the Traffic and Parking By-law, 069-1989, is amended by deleting therefrom the following:

(11) "heavy vehicle" means:

- (a) any motor vehicle having permanently attached thereto a truck or delivery body and having a gross vehicle weight, as registered with the Ontario Ministry of Transportation, in excess of 3000 kg; and
- (b) tractors used for hauling purposes on the highway, buses, motorized and mobile homes, trailers and portable offices,

but does not include a passenger vehicle, an ambulance or any Police or Fire Department vehicles.

2. That Section 1 of the Traffic and Parking By-law, 069-1989, is amended by adding thereto the following:

(11) "heavy vehicle" means:

- (a) any motor vehicle having permanently attached thereto a truck or delivery body and having a gross vehicle weight, as registered with the Ontario Ministry of Transportation, in excess of 4500 kg; and
- (b) tractors used for hauling purposes on the highway, buses, motorized and mobile homes, trailers and portable offices,

but does not include a passenger vehicle, an ambulance or any Police or Fire Department vehicles.

READ a First and Second Time in Open Council this 8<sup>th</sup> day of September, 1997.

  
Clerk

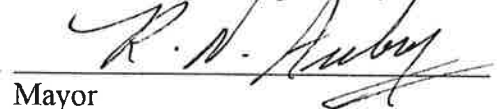
  
Mayor

READ a Third and Final Time, Signed and Sealed in Open Council this 8<sup>th</sup> day of September, 1997.

  
Clerk

  
Mayor

**BY-LAW 118-1997, OF THE CITY OF CORNWALL**

*A by-law to amend the Traffic and Parking By-law 069-1989, as amended. (Parking - Claude Avenue, Provincial Connecting Links).*

\*\*\*\*\*

**WHEREAS** The Corporation of the City of Cornwall is desirous of amending the Traffic and Parking By-law, 069-1989, in order to address parking concerns expressed by residents of Claude Avenue, and in order to deal with changes to the designated Provincial Connecting Links as a result of the downloading of the former Highway No.2.

**NOW THEREFORE** the Council of the Corporation of the City of Cornwall enacts as follows:

1. That Schedule II of the Traffic and Parking By-law, 069-1989 is amended by adding thereto the following:

HIGHWAY	SIDE	BETWEEN	TIME
Claude Avenue	South	Baldwin Avenue and a point 60.0 meters west of Baldwin Avenue	Anytime

2. That Schedule XXV of the Traffic and Parking By-law, 069-1989, is amended by deleting therefrom the following:

HIGHWAY	FROM	TO
Second Street Vincent Massey Drive	Brookdale Avenue Brookdale Avenue	Boundary Road West City limits

READ a First and Second Time in Open Council this 8<sup>th</sup> day of September, 1997.

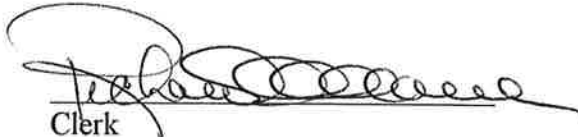
  
Clerk

  
Mayor

READ a Third and Final Time, Signed and Sealed in Open Council this 8<sup>th</sup> day of September, 1997.

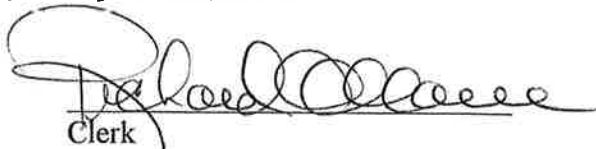
  
Clerk

  
Mayor



**BY-LAW 009-1998, OF THE CITY OF CORNWALL**

***A by-law to amend by-law 074-1993, a by-law to amend by-law 069-1989, known as the Traffic and Parking By-law, as amended pertaining to skateboarding.***

\*\*\*\*\*

**WHEREAS** the Council of the Corporation of the City of Cornwall is desirous of amending by-law 074-1993 which pertains to skateboarding; and

**WHEREAS** by-law 074-1993 amends by-law 069-1989, known as the Traffic and Parking By-law.

**NOW THEREFORE** the Council of the Corporation of the City of Cornwall enacts as follows:

1. That by-law 074-1993, reflecting amendments to by-law 069-1989, be further amended by repealing clause 45(3).
2. That Clause 45(4) and 45(5) now be identified as 45(3) and 45(4) respectively.
3. That Section 2 of by-law 074-1993 be hereby repealed which deletes Schedule XXVI (No Skateboarding Sign) from the Traffic and Parking By-law, 069-1989.

READ a First and Second Time in Open Council this 9<sup>th</sup> day of February, 1998.

  
Clerk

  
Mayor

READ a Third and Final Time, Signed and Sealed in Open Council this 23<sup>rd</sup> day of March, 1998.

  
Clerk

  
Mayor

**BY-LAW 038-1998, OF THE CITY OF CORNWALL**

**A by-law to amend the Traffic By-law 069-89 - Heavy Truck Prohibition along Sydney Street between Second Street East and Seventh Street East.**

\*\* \*\* \* \*\* \* \*\* \* \*\* \* \*\* \* \*\* \* \*\* \* \*\* \* \*\* \* \*\* \* \*\* \* \*\* \* \*\* \* \*\* \* \*\* \*

**WHEREAS** the Council of the Corporation of the City of Cornwall is desirous of amending the Traffic & Parking Bylaw No. 069-1989 dealing with Heavy Truck Prohibition along Sydney Street between Second St. E. and Seventh Street East.

**NOW THEREFORE** the Council of the Corporation of the City of Cornwall enacts as follows:

- 1. Schedule XVIII of the Traffic & Parking Bylaw No. 069-1989 is amended by adding thereto the following:

HIGHWAY	BETWEEN	PROHIBITED TIMES OR DAYS	EXCEPTIONS
Sydney Street	Second Street East and Seventh Street East	Anytime	City Transit, school buses

- 2. Section 34 (1) of the Traffic and Parking By-law No. 069-1989 is amended by adding thereto the following:

"Except as provided in Subsection (2), where official signs to that effect are displayed no person shall move, drive, park or operate a heavy vehicle as defined in Section 1, Subsection (ii) of this By-law on any highway set out in Column 1 of Schedule XVIII of this By-law, between the limits set out in Column 2 of the said Schedule during the times or days set out in Column 3 of the said Schedule, with the exceptions as set out in Column 4 of the said Schedule."

READ a First and Second Time in Open Council this 27<sup>th</sup> day of April, 1998.

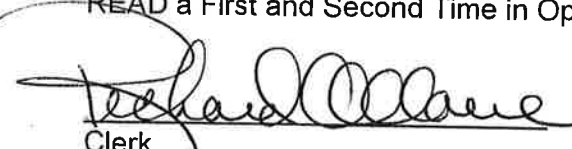
  
Clerk

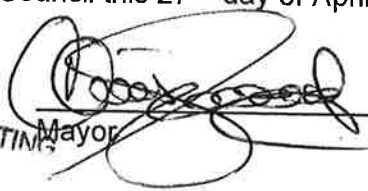
  
ACTING Mayor

READ a Third and Final Time, Signed and Sealed in Open Council this 27<sup>th</sup> day of April, 1998.

  
Clerk

  
ACTING Mayor

**BY-LAW 059-1998, OF THE CITY OF CORNWALL**

*A by-law to further amend By-law no. 069-1989  
known as the Traffic By-law  
at Cornwall Centre Road and King's Highway #138*

\*\*\*\*\*

**WHEREAS** the Corporation of the City of Cornwall is desirous of amending By-law 069-1989 ~ Traffic By-law to provide for Traffic Control Signals and Designated Traffic Lanes at the intersection of Cornwall Centre Road and King's Highway;

**NOW THEREFORE**, the Council of the Corporation of the City of Cornwall enacts as follows:

1. That Schedule XVII (Traffic Control Signals) of By-law no. 069-1989 be hereby amended by adding the following:

**CORNWALL CENTRE ROAD AND KING'S HIGHWAY #138**

2. That Schedule XII (Designated Traffic Lanes) of By-law no. 069-1989 be hereby amended by adding the following:

HIGHWAY	BETWEEN	LANE	DIRECTION	TIMES OR DAYS
Ninth Street East	Pitt Street and a point 50 meters east	Third lane from North curb	Westbound left turn	Anytime
Ninth Street East	Sydney Street and a point 50 meters west	Third lane from north curb	Eastbound left turn	Anytime
Ninth Street East	A point 50 meters east of Pitt Street and a point 50 meters west of Sydney street	Third lane from north curb	East to north and west to south	Anytime

**Read a First and Second Time**, in Open Council this 8<sup>th</sup> day of June, A.D., 1998.

  
Clerk

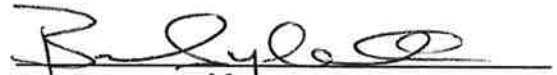
  
Mayor

**Read a Third and Final Time**, Signed and Sealed in Open Council this 8<sup>th</sup> day of June, A.D., 1998.

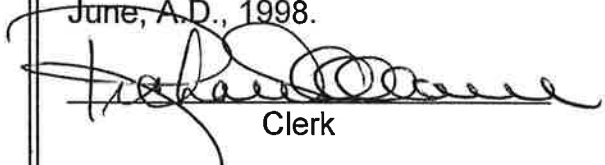
  
Clerk

  
Mayor

**BY-LAW 094-1998, OF THE CITY OF CORNWALL**

***A by-law to further amend By-law 069-1989 known as the Traffic By-law  
Parking Restrictions on Eighth Street West***

\*\*\*\*\*

**WHEREAS** the Corporation of the City of Cornwall is desirous of amending By-law 069-1989 ~ Traffic By-law to provide Traffic Control Signals and Designated Traffic Lanes at the intersection of Cornwall Centre Road and King's Highway; and

**WHEREAS** Council is provided the authority to do so pursuant to the Municipal Act, R.S.O. 1990, Sec. 102; Sec. 260, as amended;

**NOW THEREFORE** the Council of the Corporation of the City of Cornwall enacts as follows:

1. That Schedule II Parking Restrictions of the Traffic & Parking By-law 069-1989 is amended by adding thereto the following:

HIGHWAY	SIDE	BETWEEN	TIME
Eighth Street West	North	In front of St. John Bosco School	8:00 a.m. to 6:00 p.m. Monday to Friday

**READ a First and Second Time**, in Open Council this 28<sup>th</sup> day of September A.D., 1998.

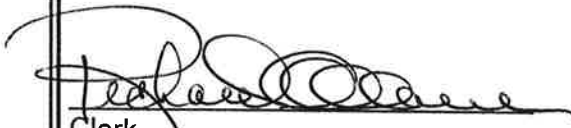
  
Clerk

  
Mayor

**READ a Third and Final Time, Signed and Sealed** in Open Council this 28<sup>th</sup> day of September A.D., 1998.

  
Clerk

  
Mayor

**BY-LAW 095-1998, OF THE CITY OF CORNWALL**

***A by-law to further amend By-law 069-1989 known as the  
Traffic By-law Parking Lots.***

\*\*\*\*\*

**WHEREAS** the Corporation of the City of Cornwall is desirous of amending By-law 069-1989 ~ Traffic By-law to provide Traffic Control Signals and Designated Traffic Lanes at the intersection of Cornwall Centre Road and King's Highway; and

**WHEREAS** Council is provided the authority to do so pursuant to the Municipal Act, R.S. 1990, Sec. 102; Sec. 260, as amended;

**NOW THEREFORE** the Council of the Corporation of the City of Cornwall enacts as follows:

1. That Schedule IX(a) Parking Meter Zones - Off-Street of the Traffic & Parking By-law 069-1989 is amended by adding thereto the following:

COLUMN 1	COLUMN 2	COLUMN 3
Parking Lot	Justice/Municipal Lot	North side of Third Street West, East of Augustus Street
Parking Lot	Zellers - Cornwallis Lot	South side of Second Street West, Part of Lot 12, between Pitt Street and Augustus Street

2. That Schedule IX (b) Attendant Parking Zones of the Traffic & Parking By-law 069-1989 is amended by deleting therefrom the following:

COLUMN 1	COLUMN 2	COLUMN 3
Parking Lot	Justice/Municipal	North side of Third Street West, East of Augustus Street
Parking Lot	Zellers - Cornwallis	South side of Second Street West, Part of Lot 12, between Pitt Street and Augustus Street

**READ a First and Second Time**, in Open Council this 28<sup>th</sup> day of September A.D., 1998.

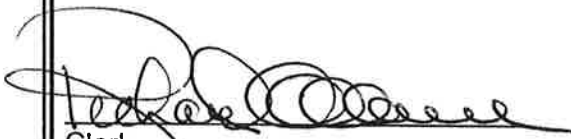
  
Clerk

  
Mayor

**READ a Third and Final Time**, Signed and Sealed in Open Council this 28<sup>th</sup> day of September A.D., 1998.

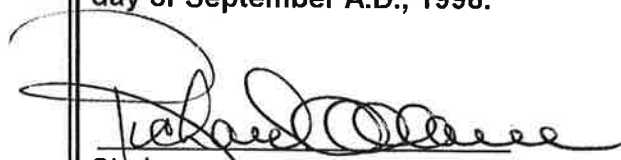
  
Clerk

  
Mayor

**BY-LAW 106-1998, OF THE CITY OF CORNWALL**

***A By-law to amend the Traffic By-law 069-1989 - Time Restriction  
in front of 24 Augustus Street.***

\*\*\*\*\*

**WHEREAS** the Council of the Corporation of the City of Cornwall is desirous of amending the Traffic & Parking By-law No. 069-1989 dealing with Parking Restrictions fronting 24 Augustus Street.

**NOW THEREFORE** the Council of the Corporation of the City of Cornwall enacts as follows:

1. Schedule IV of the Traffic & Parking By-law No. 069-1989 is amended by adding thereto the following:

Highway	Side	Between	Restricted Times or Days	Max. Period Permitted
Augustus Street	West	Front Door Entrances to 24 Augustus Street	8 a.m. to 6 p.m.	20 Minutes

2. That By-law 105-1993 be amended to reflect changes in Sec. 1.

**READ a First and Second Time**, in Open Council this 9<sup>th</sup> day of November A.D., 1998.

  
Clerk

  
Mayor

**READ a Third and Final Time, Signed and Sealed in Open Council** this 9<sup>th</sup> day of November A.D., 1998.

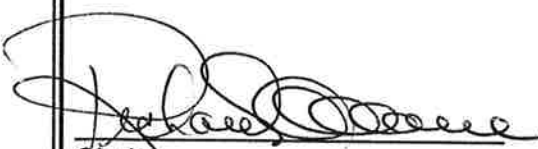
  
Clerk

  
Mayor