

REQUIRED INSPECTIONS:

1. Excavation (prior to pouring concrete for footings and foundations)
2. Footings and Foundations
3. Structural framing.
3. Final inspection once the deck is complete.

TO SCHEDULE:

Call 613-930-2787 ext. 2310 and have your name, address & permit number

MOST COMMON INSPECTION ISSUES:

- Notching of Railing Posts and improper pickets
- Stair Risers not uniform
- Splicing of beams not over support or are cantilevered
- Use of unauthorized material or system
- Unauthorized changes from permit drawings
- Use of screws where nails are required

PROPERTY ADDRESS: _____

_____ (PRINT NAME) HEREBY AGREE TO CONSTRUCT THE

DECK IN ACCORDANCE WITH THE SUPPLIED INFORMATION NOTED ON THIS DOCUMENT.

SIGNATURE: _____ (OWNER)

DATE: _____

CONSTRUCTION NOTES:

1. Construction to conform to Div. B Part 9 of the Ontario Building Code, O. Reg. 332/12 as amended.
2. Footings must bear on undisturbed soil minimum 54" below grade. ****CALL FOR INSPECTION ONCE EXCAVATION HOLES ARE DONE, PRIOR TO POURING CONCRETE.**
3. Concrete shall be minimum 15 MPa.
4. Footings shall have a minimum area of 4.3 sq.ft. (25"x25") and be a minimum of 8 1/2" thick; apart for floating decks (see floating deck information)
5. Deck foundations/sonotubes shall be minimum 8" in diameter and shall extend not less than 5 7/8" above grade and not more than 24" above grade.
6. Decks that are attached to the house shall not be attached to brick veneer, refer to detail.
7. Fasteners shall be resistant to corrosion and shall not cause splitting of wood.
8. Lumber shall be No.2 grade or better, S-P-F.
9. Columns to be minimum 6x6 wood, be centered on footings and be securely fastened using metal base shoe.
10. Provide lateral support for all beam to column connections.
11. Built up wood beams shall be nailed together with a double row of nails not less than 3 1/2" in length, space not more than 17 3/4" apart in each row with the end nails located 4" to 5 7/8" from the end of each piece OR they shall be bolted together with not less than 1/2" bolts with washers spaced not more than 3'-11" with end bolts located not more than 23" from the end of the members and splices in beams shall occur over support.
12. Beams shall NOT cantilever.
2x8 Floor joists max cantilever = 15 3/4"
2x10 Floor joists max cantilever = 23 5/8"
13. Guards shall be installed for decks that are more than 23 5/8" from effective grade. Guards to be minimum 35" for decks not more than 5'-11" above grade and shall be not less than 42" for other decks.
14. Turned pickets not permitted and pickets shall be free of loose knots.
15. Guards shall meet loading in OBC Div. B 9.8.8. or OBC SB-7.
16. Stairs with more than 3 risers shall have a handrail.
17. Stairs shall be minimum 2'-10" and stringers shall be spaced at not more than 2'-11".

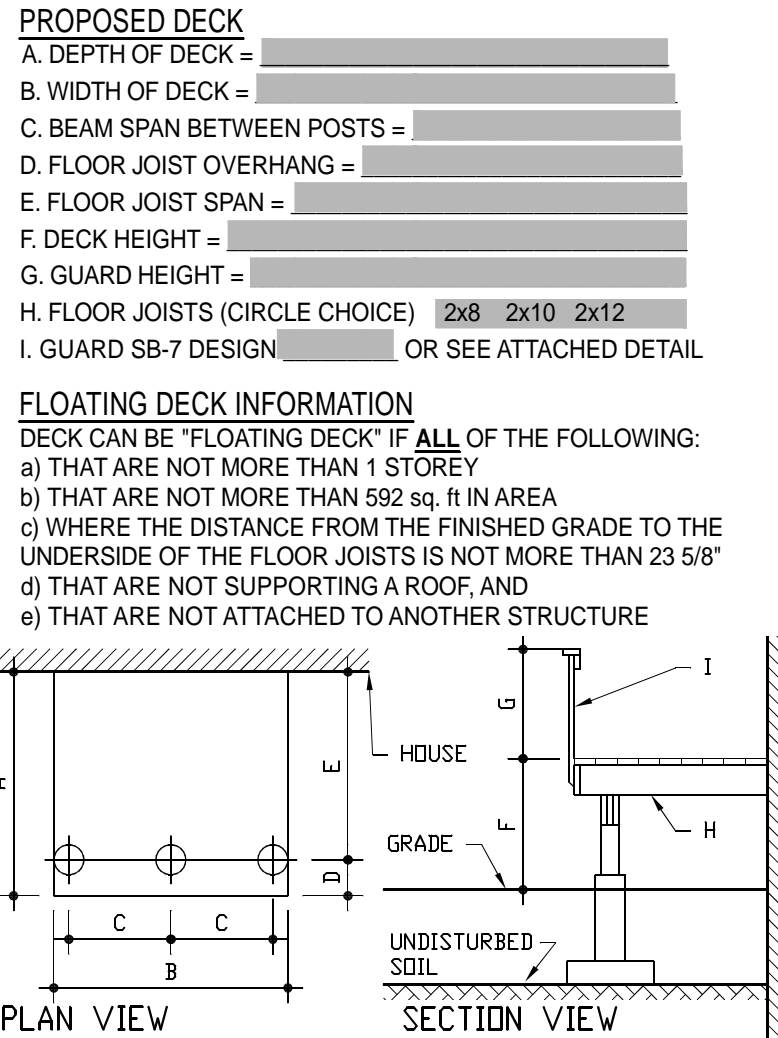

BEAM SPAN TABLE

(3) 2x8 = 9'-4" (2.85m)
 (3) 2x10 = 11'-6" (3.52m)
 (3) 2x12 = 13'-5" (4.09m)

(4) 2x8 = 10'-3" (3.14m)
 (4) 2x10 = 13'-1" (4.01m)
 (4) 2x12 = 15'-5" (4.72m)

FLOOR JOIST TABLE

2x8@12" = 11'-7" (3.54m)
 2x8@16" = 11'-0" (3.36m)
 2x8@24" = 10'-6" (3.20m)

2x10@12" = 13'-8" (4.17m)
 2x10@16" = 13'-0" (3.96m)
 2x10@24" = 12'-4" (3.77m)

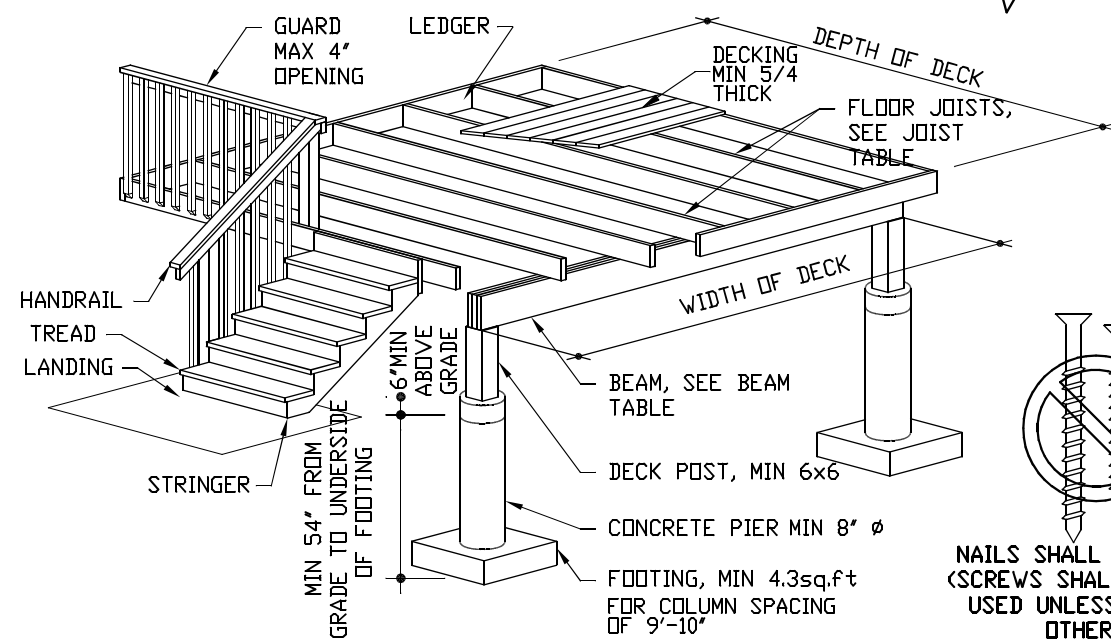
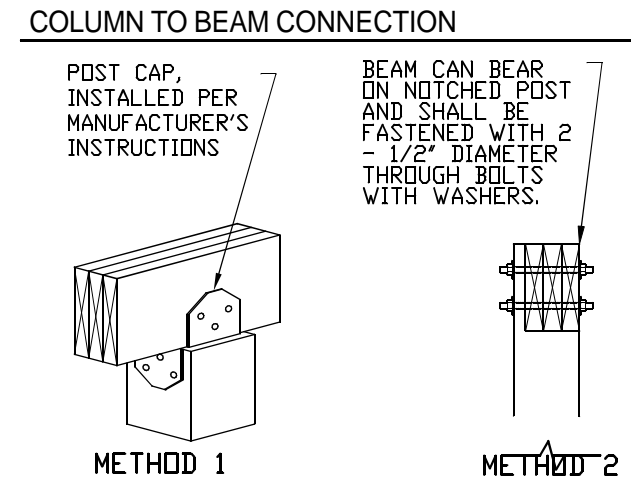
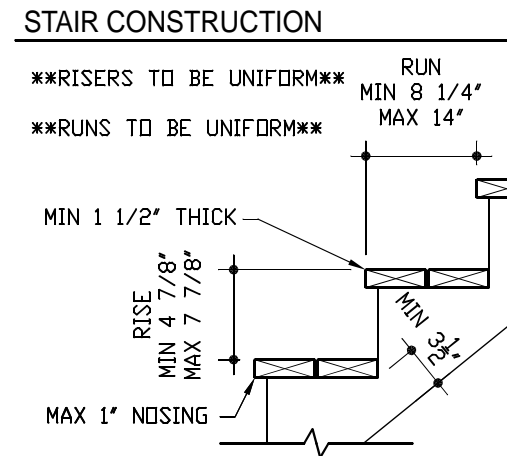
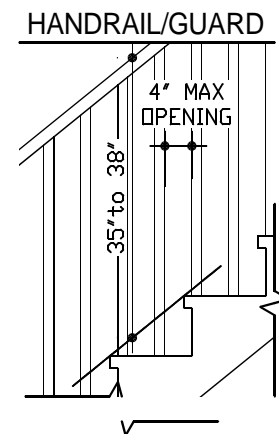
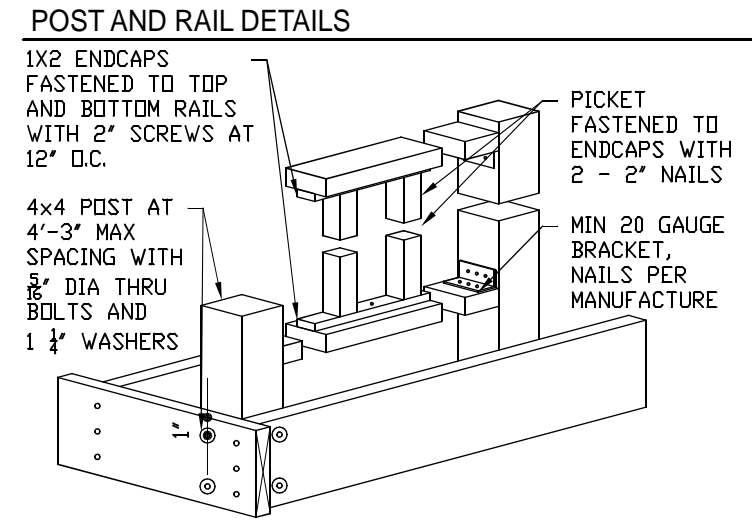
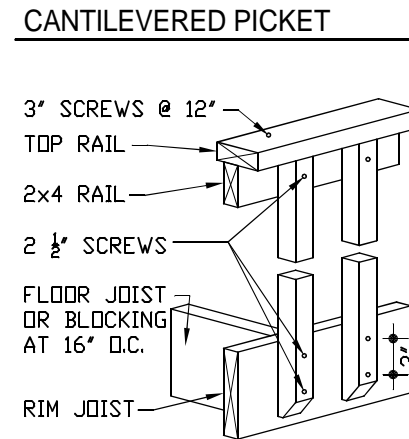

NAILS SHALL BE USED (SCREWS SHALL NOT BE USED UNLESS NOTED OTHER)

